

Spring  
2012

The Journal for Collectors

Volume 36 Number 1  
\$10.00

# OLD TOY SOLDIER

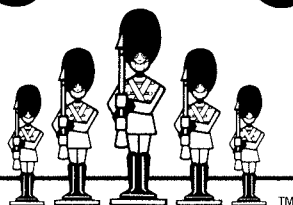

**THE SHAMUS O.D. WADE COLLECTION**

# OLD TOY SOLDIER



## AUCTIONS USA

Old Toy Soldier Auctions U.S.A.

P.O. Box 13323

Pittsburgh, PA 15243

412-343-8733

1-800-349-8009

Fax 412-344-5273

otsauctionsusa@yahoo.com

www.oldtoysoldierauctions.com

CATALOGS AVAILABLE

ONE MONTH PRIOR TO THE SALE

\$30, \$40 INTERNATIONAL

# THE TOY SOLDIER COLLECTION OF THE LATE K. WARREN MITCHELL WITH THE BOB BAILEY COLLECTION OF PRE WAR BRITAINS AND ADDITIONAL IMPORTANT PROPERTIES TWO DAY AUCTION FEATURING OVER 1000 LOTS

**Saturday, June 2, 2012**

**10 A.M. E.S.T.**

**OLD TOY SOLDIERS (DAY ONE)**

BRITAINS PRE WAR, BRITAINS POST WAR, BRITAINS PLASTICS, BRITAINS SWOPPETT, BRITAINS CIVILIANS, AEOHA PLASTIC, CHARBENS, CHERILEA, COURTENAY, ELASTOLIN, ERIKSSON, FRY, HEINRICH, HEYDE, IMPERIAL, JOHILLCO, KING AND COUNTRY GLOSSY, KING AND COUNTRY MATTE, KROLYN, LINEOL, MARX, MIGNOT, MINIKIN, ROSE, SACUL, S.A.E, SEGAL, STADDEN, TAYLOR AND BARRETT, TIMPO, WENDALL, VERTUNNI, PLUS OTHERS

**Sunday, June 3, 2012**

**10 A.M. E.S.T.**

**NEW TOY SOLDIERS (DAY TWO)**

ALYMER, BANNERS FORWARD, BLENHEIM, BRITAINS, CONTE, DELI DURBAR, EAST OF INDIA, EDEN STUDIOS, EDMUNDS, FRONTLINE, FUSILIER MINIATURES, HIRIART, HORNING ART, IMPERIAL, KING CAST, KING & COUNTRY, LITTLE LEGION, MARLBOROUGH, MARTIN RITCHIE, PICKLEHAUBE, RUSSIAN MINIATURES, SOLDIERS OF THE WORLD, SOMMERSET MINIATURES, STEADFAST, TOMMY ATKINS, TRADITION, TROPHY, AND MORE....



Trophy Officers Encampment



Elastolin Noah's Ark



Timpo  
Uncle Mistletoe

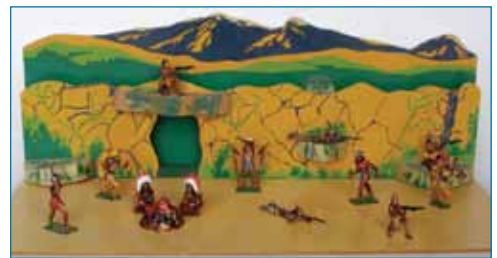

Johilco Indian Camp



King and Country



Johilco Crusaders



Fry Trees Etc.



Britains Delivery Van



Vertunni



King Cast Royal Marine Band



Britains Racing Colours



Heyde Dogs/Cat Jockeys



Britains Adult Giraffe

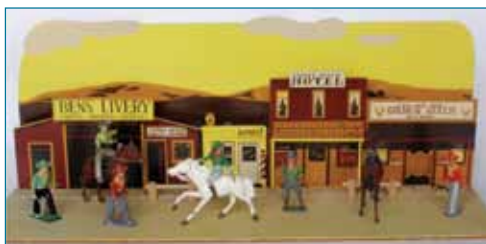

Johilco Western Town



Johilco Display Sets



Krolyn



Timpo Crusaders

**View this auction and purchase catalogs on our website: [oldtoysoldierauctions.com](http://oldtoysoldierauctions.com)**



Ray Haradin

412-343-8733 • 1-800-349-8009

Fax 412-344-5273 • raytoys@aol.com

Norman Joplin - Day 1

262-692-3913

otsauctionsusa@yahoo.com

Joe Saine - Day 2

419-662-8697

josephsaine.com

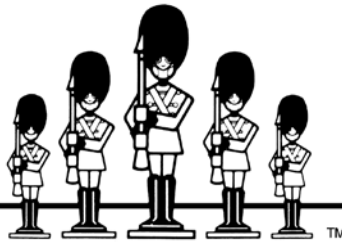

oldtoysoldier.com

**Old Toy Soldier** is published quarterly.

**Publisher**

Ray Haradin raytoys@aol.com

**Editor**

Norman Joplin info@normanjoplin.com

**Advertising**

Ray Haradin raytoys@aol.com

**Circulation**

Nancy Haradin raytoys@aol.com

**Technical Production**

Banksville Express Printing

**Proofreader**

Roberta Haradin

**Staff Photographers**

David Haradin  
Noel Schlageter

**Staff Cartoonist**

Sue Joplin

**Show Reports**

Ray Haradin, Norman Joplin, Noel Schlageter

**General Inspection-New Product Review**

Russ Bednarek

*Old Toy Soldier* is printed by  
Banksville Express Printing  
Pittsburgh, Pennsylvania, USA

**Specialist Contributors**

Rob Wilson and Joe Wallis, Britains Military  
Louis S. Steinberg, Richard O'Brien and  
Stan Alekna, Dimestore Figures

Correspondence, including Manuscripts, Trade and  
Toy Soldier Marketplace Advertisements and all  
general inquires, should be forwarded to:

Old Toy Soldier  
P. O. Box 13324  
Pittsburgh, Pennsylvania 15243-0324  
Telephone (412) 343-8733  
Fax (412) 344-5273  
E Mail: raytoys@aol.com

Copyright 2012, Old Toy Soldier. Publisher Ray Haradin. All rights reserved. Entire Contents Copyright 2012, Old Toy Soldier. Copyright includes, but is not limited to, print media, microfilm, and electronic media, such as CD-ROM's and online computer services.

ISSN1064-4164

**IN THIS ISSUE**

**VOLUME 36 NUMBER 1 - SPRING 2012**

**ARTICLES**

G.W. WOOD & CO. THE FORGOTTEN  
MANUFACTURER PART 2.  
AND A VISIT TO THE NATIONAL ARCHIVES  
IN LONDON

*By Norman Joplin* ..... 8-12

SHAMUS WADE - AUCTION PREVIEW  
TOY SOLDIER AND FIGURE AUCTION

*By Norman Joplin* ..... 18-20

ABOVE THE BATTLEFIELD  
PART I: PRE-1918 GERMAN-MADE AIRSHIP SETS

*By Earl Jorgensen*..... 36-40

FRANKLIN MINT ADVERTISING FEATURE  
THE AMERICAN FIGHTING MEN.....42

J.S.H., THE MYSTERIOUS ILLUSTRATOR  
*By Joe Wallis* ..... 49-51

ROGER ALLEN JOHNSON 1932-2009  
DREAMT OF DIMESTORES THAT NEVER WERE...  
AND IMAGINATIVELY SAID WHY NOT!

*By Louis S. Steinberg* ..... 53-57

PROTOTYPE OF MANOIL'S NO. 702 COUPE  
*By Stan Alekna* ..... 61-63

**FEATURES**

Hobby News ..... 7

Show Reports.....23-26

Auction Review/Previews ..... 14-21

Book Reviews.....43-45

Toy Soldier Market Place .....66-67

Toy Soldier Show and Auction Calendar ..... 68

Advertisers Index.....69-70

Subscriptions .....71-72

**ON THE COVER**

The Shamus O.D. Wade Collection  
Photograph courtesy of Philip Dean







VOLUME 31



NUMBER 1



NUMBER 2



NUMBER 3



NUMBER 4

VOLUME 32



NUMBER 1

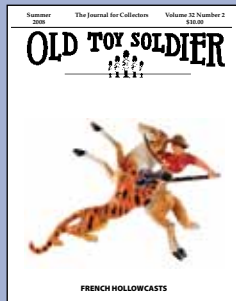

NUMBER 2



NUMBER 3



NUMBER 4

VOLUME 33

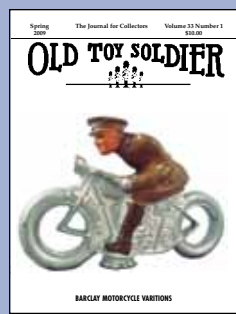

NUMBER 1



NUMBER 2



NUMBER 3



NUMBER 4

VOLUME 34

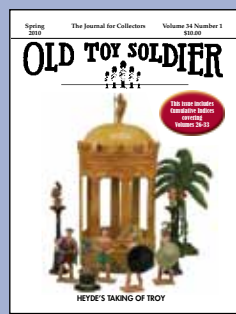

NUMBER 1



NUMBER 2



NUMBER 3

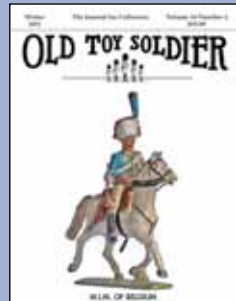

NUMBER 4

VOLUME 35



NUMBER 1

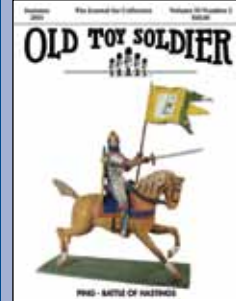

NUMBER 2

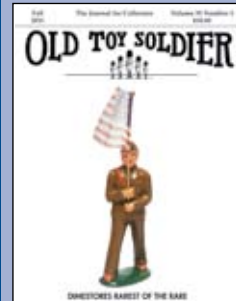

NUMBER 3

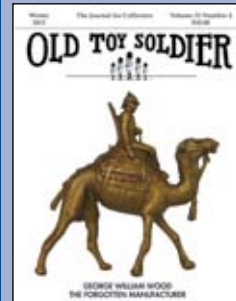

NUMBER 4

OLD TOY SOLDIER BACK ISSUE ORDER FORM

Name \_\_\_\_\_ Phone \_\_\_\_\_

Address \_\_\_\_\_ Email \_\_\_\_\_

City \_\_\_\_\_ State \_\_\_\_\_ Zip \_\_\_\_\_

Back issues are \$10.00 each, postage included. All international subscribers add \$15.00 to order total. Four or more issues - \$7.00 each. Only a limited supply of back issues exist. Order today! Back issue payments should be in US dollars.

Volume 31  #4

Volume 32  #1  #4

Volume 33  #1  #2  #3

Volume 34  #1  #3  #4

Volume 35  #1  #2  #3  #4



Checks payable to: Old Toy Soldier  
P.O. Box 13324  
Pittsburgh, PA 15243-0324

Email: raytoys@aol.com

MasterCard, Visa, American Express and Discover credit cards accepted

Card No. \_\_\_\_\_ Exp. Date \_\_\_\_\_

TOTAL \$ \_\_\_\_\_

# An Old Toy Soldier's Soldiers

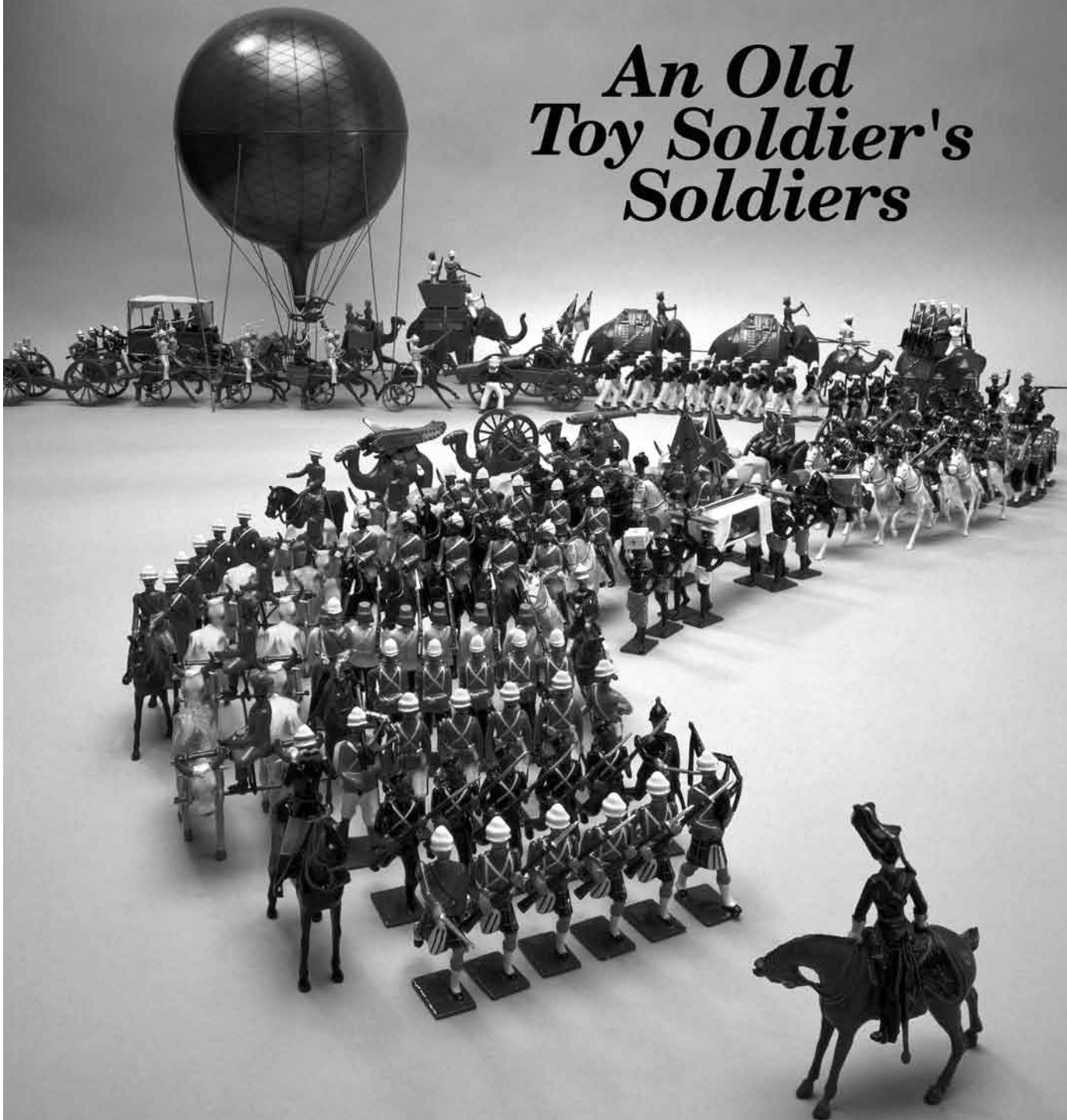

Time was a toy soldier knew what it meant to be a toy soldier. All spit and polish, bright shiny uniform, lean and rugged, big pink cheeks, manual-of-arms, upright and proper even in the din of battle. Most new toy soldiers - a sorry lot. No group discipline, dull and wrinkled uniforms - refugees from some old diorama. And fat. Half seem to be dying. Can't speak English - Russian or Chinese more'n likely.

Right. Well our troops still pass muster. Our men know how to march together and how to fight together and look smart doing it. Our men want to be thrown onto the battlecarpet and properly pummeled like the toys they are - not given some shelf job commanded by a namby-pamby "connoisseur". Our men can take it and still shine. Our men know what it means to be a real toy soldier.

The Toy Soldiers of



Wm. Hocker, Proprietor

<http://wmhocker.com>





## *Virginia's Largest Military Base is in Williamsburg.*

See the world's greatest armies standing side-by-side in our incredible collection of military miniatures, featuring W. Britain, King & Country, Frontline Figures, John Jenkins Designs, Wm Hocker, and others, including old toy soldiers. And check out all our unusual toys. With shops in Williamsburg and online, it's easy to deploy these troops to your home.



*Exceptional Toys and Collectibles for All Ages*

415 W. Duke of Gloucester Street, Merchants Square, Williamsburg, VA 23185  
757-229-5660 Toll Free 800-343-8697

[www.toymakerofwilliamsburg.com](http://www.toymakerofwilliamsburg.com)





Treefrog Treasures presents

# Beau Geste

New Toy Soldiers  
Traditional Style Metal Toy Soldiers

In Stock  
Available for  
Immediate  
Shipping

Delhi Durbar 1903

World War I

Napoleonic

Boxer Rebellion  
Russo Japanese War

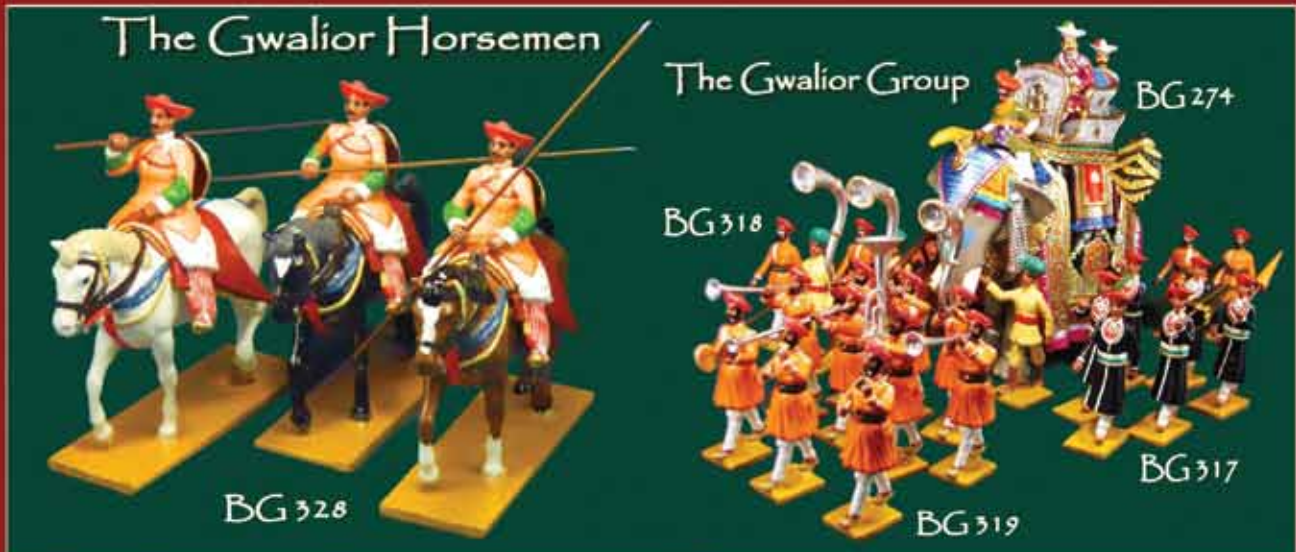

Full online catalog at [www.treefrogtreasures.com](http://www.treefrogtreasures.com)

Shannon Reuss [sales@treefrogtreasures.com](mailto:sales@treefrogtreasures.com)

Toll Free (866) 394-2418

International 1 - (507) 545-2500

Free International Shipping on orders over \$250!

Free Domestic Shipping on orders over \$50!



# HOBBY NEWS

## OBITUARY HANS HENNING ROER

Dr. phil., Pharm. Rat, retired

Dr. Hans Henning Roer passed away suddenly at the age of 74 on the 29th of Feb. 2012.

For all collectors who knew him personally, he was one of the gentlemen of our hobby and an avid collector. For some, who had the pleasure to know him better, he was also a good friend and mentor in terms of old Lead Soldiers. He shared his knowledge and expertise to everybody, especially new collectors.

Dr. Roer's first book "Bleisoldaten" published in 1981 contained information on old lead figures produced in Germany and brought forth information previously not available to none German-speaking collectors. His second book, "Old German Toy Soldiers",



was issued in 1993 and found further International acclaim because of the multilingual text.

Playing with toy soldiers was his great passion. Under the old rules

of a "Table game" by Hausser Circa 1920 containing great scenes of past battles, alive with ancient Toy Figures.

Dr. Roer won many friends in the hobby as true gentleman in love with toy soldiers.

Everyone who knew him personally will remember his peculiar sense of humor and his friendly manner.

Our deepest sympathy to his wife Annie and their families.

Dr. Hans-Henning Roer will be sadly missed.

This obituary was submitted by Gisbert Freber.

## OTS AT THE CHICAGO SHOW OLD TOY SOLDIER AUCTION'S SPECIAL EVENT.

The single figure collection of the late K. Warren Mitchell and other prominent collectors will be for sale at a special event on Friday, September 21st at the Hyatt Regency. A two hour window has been allocated in the afternoon, on Friday the 21st. The sale will be located on the fourth floor of the hotel - more info in *Old Toy Soldier*, August edition.



SATURDAY, SEPTEMBER 22ND  
OTS BARGAIN ROOM  
AT THE CHICAGO SHOW 10 AM.

*Advance Notice*

OLD TOY SOLDIER AUCTION  
*June 2nd & 3rd, 2012*

OLD TOY SOLDIER



AUCTIONS USA



# G.W. WOOD & CO. THE FORGOTTEN MANUFACTURER PART 2.

## AND A VISIT TO THE NATIONAL ARCHIVES IN LONDON

By Norman Joplin

In Part one of the **G.W. Wood** Story published in *Old Toy Soldier* Magazine Volume 35 # 4 Winter 2012 I documented the discovery that the British Camel Corp figure, previously attributed to companies other than **G.W. Wood** had in fact been produced by that company.

The information was based on the discovery of a figure with a printed number on the casting and my search at the National Archives in London proved that maybe there was a lot more to uncover both on Mr. Wood and possibly on other early toy soldier manufacturers before, during and immediately after World War 1.

I visited the National Archives again in March 2012 and spent almost 5 days researching in the hope of finding more information on **G.W. Wood and Company**, my discoveries, as mentioned in the previous issue of OTS had led me to conclude that Mr. Wood was in fact a major player in toy soldier manufacturing business during those "Great War" years. Not having a registration number to work with the following system must be carried out.

### March 2012 National Archives Discoveries.

**Note -Brushfield Manufacturing Company** is henceforth referred to as **BMC** in this article.

My research to date in relation to **G.W. Wood** is as follows. The links between **Mr. Wood, BMC (Brushfield Manufacturing Company) and John Hill** are best described by the following time lines;

**1912 BMC** Incorporated in 1912 listed as in Kelly's London Post Office Directories as manufactures of leather goods - **no mention of Toy Soldiers.**

**1913 G.W. WOOD** Listed in *Directory of Toys and Games* Manufacturers as Metal Toy Manufacturers & Wholesalers. Address New North Road London.

**1913. March, May and September** advertisements for **G.W. Wood** appear in *The Toy and Fancy Goods Trader*, a discovery made during earlier research at the British Museum Newspaper Library in Collindale London. Although these ads show the **G.W. Wood Mounted Cowboy** the design was not registered by the Board of Trade and allocated a number (615928) until December 15th 1913.

SUPERIOR

## Metal Models

TYPES OF  
THE BRITISH ARMY.

### Manufactures

ALL NEW LINES.

*SOLDIERS (all regiments),  
COWBOYS, BOY SCOUTS,  
INDIANS (Mounted and on Foot),  
GIRL SCOUTS, ZULUS.*

Boxes to retail from 3½d. to 5/- per Box.

### WHOLESALE ONLY.

## G.W. WOOD & CO.,

139, New North Road, London, N.

Personal Attention given to all Orders.		Moderate Prices. Quick Delivery. Prices on Application.
<h2>G. W. WOOD &amp; Co.,</h2> <p style="text-align: right;">139 New North Road, N.</p> <p style="text-align: center;">Manufacturers of Metal Toys, Soldiers &amp; Novelties.</p>		
<p>New Lines Now Ready</p> <h2>COWBOYS</h2> <p>with Lasso.</p>		
<h3>6d. and 1/- Boxes of Soldiers a Speciality.</h3> <p>New Lines in <b>BOY AND GIRL SCOUTS.</b></p> <p>See these lines before applying to other makers.</p>		



# G.W. WOOD & CO. THE FORGOTTEN MANUFACTURER (Cont.)

**1913. March May and September** the listings in these ads refer to, but do not illustrate other items available from **G.W. Wood**, which later appear in the undated **BMC** listings page see below.

**1913 May 5th** Indian Mounted on rearing Horse registered by Board of Trade on behalf of **G.W. Wood** (# 618584)

This item has subsequently been found as part of a range of figures produced early post World War Two by **B&T The Toys for Boys** and can be viewed in the relevant chapter in my book the *Great Book of Hollow Cast Figures*. **B&T The Toys for Boys** bought up post war moulds from defunct companies and provided mixtures in boxed sets and in profusion to Woolworths Stores in the UK. A similar Cowboy on a rearing horse it must be assumed, was originally a **G.W. Wood** product.



**1913 December 15th**

Mounted Cowboy registered by the Board of Trade on behalf of **G.W. Wood** (#615928) See above when this item was illustrated in *The Toy and Fancy Goods Trader* March, May and September 1913.



**1914. February 17th G.W. Wood.** Camel Corps Figure (# 632428) documented as being registered with the Board of trade.



**1914 February 17th G.W. Wood** World War One Soldier walking with Bicycle (# 632427) registered on behalf of **G.W. Wood**. This was the last entry for **G.W. Wood**. See notes 1917 January below.



**Undated BMC** Listing showing Regiments of the British Army by BMC with seemingly added references identical to those mentioned in the G.W. Wood advertisements of 1913.



BRITISH CAVALRY, in 6d. & 1/- Boxes. Made in all Regiments as undermentioned.



BRITISH INFANTRY, in 6d. & 1/- Boxes. Made in all Regiments as undermentioned.

LIST OF REGIMENTS that can be obtained in the B.M.C. Series of London made Models of the British Army.

In ordering, it is sufficient to quote the number only.  
For 1/- Boxes add /12 after the number. Thus—101/12 for 1/- box.  
For 6d. Boxes add /6 after the number. or 101/6 for 6d. box.

## FOREIGN REGIMENTS.

Austrian Infantry (Blue).  
Russian Cavalry.  
Russian Lancers.  
Austrian Infantry (Service).  
German Infantry (Blue).  
German Infantry (Service).  
French Cuirassiers.  
French Infantry.  
Polish Infantry.  
Russian Cavalry (Cossacks).  
Russian Infantry.

Also a large assortment of 6d. & 1/- Boxes of  
Indians and Cowboys, Mounted and Foot.  
Zulus.  
Boy Scouts.  
Girl Guides.

A Large Variety of 1/2d. and 1d. Lines.

Handsome displayed BOXES OF ASSORTED  
SOLDIERS, SAILORS, SHIPS, &c.,  
to retail from 6d. to 10/6.  
TOY TENTS, to retail from 1d. to 6d. each.

# G.W. WOOD & CO. THE FORGOTTEN MANUFACTURER (Cont.)

**1914 May 29th.** First Design for **BMC** -- Highland Piper (637748) and **BMC** Kneeling Boy Scout with pole (637749).



**1914 October 9th. John Hill**  
Austrian with moveable arm (642681)



**1914 November 17th. John Hill**  
Mounted Arab on Horse (643831)

**1914 August 26th. BMC** Registered Design for Battleship (641397)



**1914 November 17th. John Hill** Kneeling Highlander (643842)



**1914 September 14th.** First entry for **John Hill** Lying Highlander (641962)

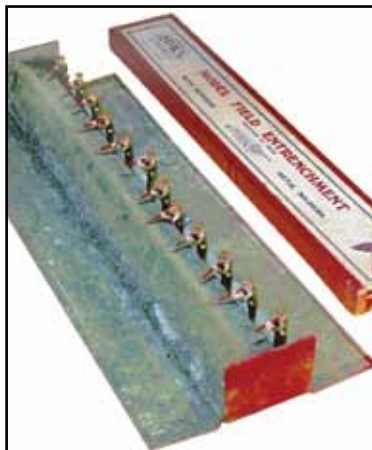

**1914 November 30th. BMC** Trench & Figures (644185)



**1914 September 14th. John Hill** Khaki Drummer in Foreign Service Helmet (641963)





# G.W. WOOD & CO. THE FORGOTTEN MANUFACTURER (Cont.)



1915 January 13th,  
John Hill Charging  
Highlander ( 645163)

**NOTE: IF ANYONE HAS AN EXAMPLE OF THIS ITEM PLEASE CONTACT OTS MAGAZINE.**

No further entries were found until ---

**1917 January 15th.** Disappointingly a pencil entry rather than a pen entry in the Board of Trade ledgers giving 5 design numbers for **BMC** could not turn up actual designs and with the entry being in pencil it seems designs were not registered.

Entries for all 3 companies in the National Archives ledgers stop after January 1917 as not all WW1 info was available for all companies according to the National Archives.

Further research needs to be carried out on my next visit to the National Archives to see if other designs for **G.W. Wood, BMC and Hill** are included before or after January 1917.

## OTHER RELATED RESEARCH

**1915 BMC** Listed in Directory of Toys and Games Manufacturers and Wholesalers as Metal Toys Manufacturers. Address 6-8 Radsworth Street, London EC.

**1915 G.W. Wood** no longer listed in Directory of Toys and Games Manufacturers and Wholesalers as Metal To Manufacturers.

**1915 to 1917 BMC** listed in Kelly's London Post Office Directory as manufacturers of the BMC line of Metal Soldiers.

**1918 Hill Incorporated** "around" according to Companies House Cardiff UK but records destroyed. Incorporation # 153348

**1918 -1921. BMC Brushfield Manufacturing Company** Still listed but no mention of **BMC** range of Toy Soldiers

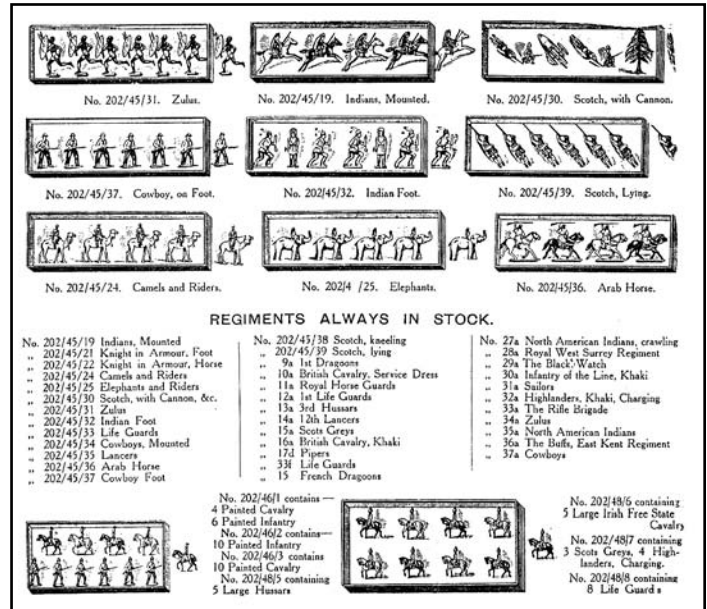

A **Hill** catalog sheet showing what appears to be **BMC** figures in the listing, dated around post 1922 because of the inclusion of the Irish Free State Cavalry.

**1921. No listing for BMC** in Kellys London Post Office Directory.

**1921 March. Soldarma**, a trade name apparently used for BMC and sometimes used on boxed sets, was mentioned in an editorial in Games and Toys Magazine and listed as being exhibitors of Toy Soldiers at the British Industries Fair with over 200 models on view including Mexicans, Sailors, Belgian and French Soldiers, Marines. The article also states that Queen Alexandra purchased a box of soldiers from them. The address listed for the company being 12 Hyde Road Hoxton London and the Managing Director being listed as Mr. Pickford.  
**1921 July 12th The Soldarma Company**, a trade name used by **BMC** was reported in the London Gazette to have been voluntarily wound up.





# G.W. WOOD & CO. THE FORGOTTEN MANUFACTURER (Cont.)

## SUMMARY SPECULATION

**G.W. Wood** joined his brother **FH Wood ( Hill)** and was designing and registering for **BMC and Hill** after stopping production as **G.W. Wood and Co.**

The word superior appears on boxes by **G.W. Wood, BMC, Soldarma and Hill** providing another connection to all four companies



A Hill box label from around 1915

Several items by **Arthur Fry** - (See part three of this article in August OTS) are more in scale with **GW Wood / BMC** and could possibly have been made on his behalf by either company.

## THE NATIONAL ARCHIVE SYSTEM

At this point it seems a good time to share and help unlock the key to navigating the National Archive System. One must first obtain a readers ticket and a carded ID before entering the vast reading rooms situated on two floors of the building. You must reserve a seat and desk which is yours for the duration of your visit.

The relevant information when searching for manufactures can be found by accessing the Board of Trade directories, which in turn give you access to the representations files or images, these being the original drawing, photo or item that was submitted when applying to register a design.

Using the computer records a Board of Trade code number for the date of the hand written ledger where each application was registered must be obtained and ordered. The retrieval system for each item takes about 40 minutes after you have found

the number of the ledger that you require, you then must check the computer to see if your item had been retrieved and placed in a collection box linked to your seat location within the archives.

Ledgers are held on the first floor and can be picked up at a desk from the staff at which point you may browse the ledgers for as long as you wish before returning them. You may order three ledgers at a time, but only take one at a time to view.

In order to find the company names, which are recorded in date order, it's a case of paging through each large hard bound ledger. The hand written company name entries are random/by date and until you find the name of a company that interests you there is no way of knowing the design number. There is no index in the ledgers and no short cuts, it's simply a matter of going through each page of each ledger until something of interest shows up.

Once a design number is found listed against the company you are researching then note must be made of the number to enable you to return to the computer and order the relevant file where the design should be housed. Another 40 minutes at least goes by for this to be retrieved before you actually get to look at the file and hopefully find the image of the design you want. It is slow and much patience and dedication is needed as it may be that there are no entries for what your searching for, so it's a case of back to square one and order another ledger and wait another 40 minutes etc etc etc.

Copies such as those illustrated in this article can be ordered from the reprographics department and emailed to you as digital images.

The National Archive building situated near Kew Gardens on the outskirts of London is a modern purpose built building with Museum, Cafe, Gift shop & restaurant, so there is plenty of opportunity to refresh and enjoy a coffee or a bite to eat whilst waiting for the documents to arrive in your retrieval box. The building is closed on Mondays and Public Holidays, it is open 9am to 5pm Monday, Wednesday and Saturday and 9am to 7pm Tuesday and Thursday.

Getting to Kew from central London is best by Underground or Tube as it is called, Take the Central Line to Richmond via Kew which is the second last stop, with an out of rush hour journey time being about 30 minutes.

*Photographs courtesy of Philip Dean*

# RODNEY'S DIMESTORE GALLERY

- OVER 3800 ACTIVE LISTINGS FOR SALE
- AMERICAN DIMESTORE VINTAGE & CONTEMPORARY FIGURES
- ARGENTINEAN, FRENCH, JAPANESE HOLLOWCASTS
- FIGURATIVE CAST IRON

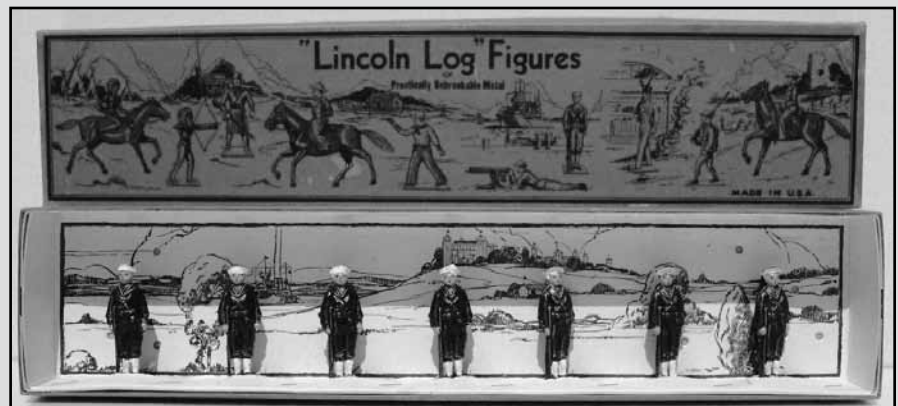

**I buy collections of any size**  
**Website address: [rodneysdimestoregallery.com](http://rodneysdimestoregallery.com)**  
**email: [castings1@att.net](mailto:castings1@att.net)**  
**2937 Rosa Del Villa Drive, Gulf Breeze, Florida 32563**  
**850-932-6522**



# Old Toy Soldier Auctions Issues a Call to Muster on June 2-3 for Major Offerings from the Collections of Bob Bailey and the Late K. Warren Mitchell

**P**ITTSBURGH – ARMCHAIR generals and commanders of upscale bathtub fleets worldwide will show their firepower over the weekend of June 2-3 during a very special Old Toy Soldier Auctions event containing 1,200+ lots from several choice collections. Headlining the auction are soldiers from the collection of the late K. Warren Mitchell, plus the Bob Bailey collection of prewar Britains and other important properties from US and international consignors.

OTSA owner Ray Haradin described the headliner collections as “an excellent match, since each brings something distinctly different to the mix.”

Bob Bailey, a Seattle collector who has been active in the toy soldier hobby his entire life, focused his efforts almost exclusively on early Britains. While working as a Pan Am flight attendant in the 1970s, Bailey wisely took advantage of his many layovers in London to scour the shops for

Britains productions.

The late K. Warren “Mitch” Mitchell, who was from Warren, Ohio, was a respected veteran dealer and collector who began his buying and selling adventures in the 1970s.

“Mitch sold actively at shows until about the last four or five years of his life, and for many years he had one of the most widely distributed specialty sales lists in the world. I know of many collectors who bought their first set of soldiers from him, and his longtime presence in the hobby has created a lot of interest in the pieces we will be selling from his collection,” said Haradin.

Haradin added that around 100 additional lots from the Mitchell collection will be offered in OTSA’s November sale, with yet another selection from the Mitchell trove to be offered under the joint banner of OTSA and Joseph Saine’s Michigan Toy Soldier in a live, non-cataloged July 21 auction.

Day one of the June 2-3 auction comprises approximately 700 lots of toy soldiers made prior to 1970. Day two will cover the production period from 1970 to present day.

Among the opening sessions’ many desir-

*FAR LEFT: Britains Set 102 Grenadier Guards, Scots Guards, Irish Guards display, prewar, 33 pieces, gold-and-black label box, est. \$3,000-\$4,000.*

*LEFT: Britains Set 2070, US Civil War boxed display set. Union and Confederate cavalry, infantry, artillery. Thirty pieces, est. \$800-\$1,200.*

*BELOW, left: Britains Set 1870 Historical Series Collection, one of eight different boxed sets from this series to be auctioned. Extremely rare. Est. \$2,000-\$2,500.*

*BELOW, right: Timpo Exceptionally RARE Ivanhoe Set # KN 4 Containing Mounted Ivanhoe, Sir Brian De-Bois Gilbert, Sir Philip De Malvosin, Sir Hugh De Bracy, Ralph De Vipont and Front De Boeuf, all with detachable Lances. Post War with Original Box Untied. 6 Pieces. Condition Excellent. Box Very Good. \$1500-\$1800.*





**RIGHT: Cherilea Baseball Set B/100, 11 figures tied in original box, est. \$1,500-\$2,000.**

**FAR RIGHT: Salco circa-1950 Disney boxed set with Mickey Mouse and Donald Duck in the garden with wheelbarrow and garden tools. Est. 350-\$450.**



able highlights from the Bailey collection is a prewar Britains boxed set 102. Made around 1920, the 33-piece assemblage includes Grenadier Guards, Scots Guards and Irish Guard and is presented in a set box emblazoned with a spiffy gold and black printer's label depicting the British Army. It is estimated at \$3,000-\$4,000.

Also from the Bailey collection, there will be eight sets from Britains' 1940 Historical Series made expressly for FAO Schwarz toy store in New York. "Eleven sets were produced in total for the series. Basically, Britains designed the sets as samplers, choosing figures that were already included in other sets. Each figure is identified at the lower edge of the box below its particular slot. These sets are very rare, and to have eight of them in one collection is remarkable," said Haradin. The estimate range on the sets runs from \$1,800 to \$3,000.

One of the most exciting of the non-Britains sets entered in the June 2 session is a very scarce Timpo Ivanhoe set KN4. The coveted grouping of mounted figures includes Ivanhoe, Sir Brian De Bois Gilbert, and four others from the 12th-century Saxon warrior's inner circle. Haradin said he has only ever seen one other set and that the set to be auctioned is the first he has encountered that actually includes the Ivanhoe figure. Estimate: \$2,000-\$2,500.

Another lot that is expected to draw widespread interest is the exceptionally rare Cherilea Baseball set that includes the entire team plus umpire, housed in the original box. Ironically, the set was produced in England, where bats are meant for cricket, not baseball. Haradin explained that after World War II, many English companies were producing goods for the stronger American market. The Cherilea set could drive in a winning bid of \$1,500-\$2,000.

An ever-popular Buck Rogers set includes the space-

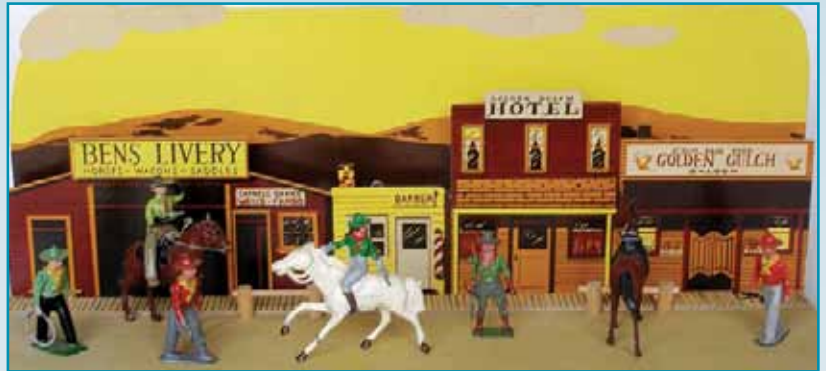

**ABOVE, top: Britains prewar Buck Rogers set including figures of Buck with ray gun, Wilma, Ardala, Dr. Huer, 'Killer' Kane and seldom-seen Mekanoid Man robot. Est. \$2,500-\$3,500.**

**ABOVE, botom: John Hill (Johillco) for British Mid West Importers Cowboy Town façade and baseboard, complete with mounted and standing cowboys and cowgirls. Est. \$800-\$1,200.**

**BELOW, left: King & Country Afghanistan Humvee with captive SF03, 5-piece set with box, est. \$150-\$200.**

**BELOW, right: Elastolin Noah's Ark set with 24 figures, including Noah and wife, this is the largest of the three ark's that Elastolin produced. est. \$800-\$1,200.**





*LEFT: Heyde Fall of Troy set (partial), with the Temple of Troy building and some key figures, est. \$2,000-\$3,000.*

*RIGHT: Heyde circa-1905 80mm large-scale US Gun Team at the Halt, includes two horses pulling limbered wagon with cannon and mounted officer. Est. \$3,500-\$4,500.*

man's sidekicks and additional characters: Wilma, Ardala, Dr. Huer, the evil "Killer" Kane and robot Mekano Man. The appearance of a Buck Rogers set at auction always ignites a bidding war between Britains collectors and space toy enthusiasts. The six-piece ensemble is expected to reach \$2,500-\$3,500 on June 2.

A great surprise lies in wait for collectors who like to show off their figures in settings – four Johillco for British Midwest Importers display sets. They depict, respectively: Cowboy Town, Indian Camp, Beachhead, and Crusaders with Castle. Each set comes with its correct figures – ranging from nine figures with the Old West Cowboy Town to 14 each for Beachhead and Crusaders – and is estimated at \$800-\$1,200.

"We've had a lot of calls about the Johillco sets based solely on our preview brochure," said Haradin. "These particular display sets are very rarely seen. Previously, I had seen only one such set. Collectors love when rarities come out of the woodwork and they're able to vie for them in a public forum."

King & Country is a brand whose star keeps rising with collectors. In particular, buyers seem to favor glossy, pre-1990 examples. Fourteen sets of glossy figures will be sold on day one, with many additional King & Country lots earmarked for day two.

Collectors of German figures won't want to miss the Heyde Fall of Troy set (partial), with the Temple of Troy building and some of the key figures intact. Estimate \$2,000-\$3,000. Also by Heyde, a circa-1905 80mm large-scale US Gun Team at the Halt includes two horses pulling a limbered wagon with cannon, and is led by an officer on

his mount. Considered one of the larger sets in that scale, it is entered with a \$3,500-\$4,500 estimate.

The opening session is rounded out with 20 mounted Lucotte French court figures, from a high-end range by Mignot CBG, est. \$200-\$400 each; 20 very fine Courtenay medieval knight figures, both mounted and unmounted, est. \$100-\$600; and a nice sampling of Lou Steinberg dime store figures.

Sunday's 500+ lots present a virtual panorama of contemporary toy soldiers. Highlights include a terrific lineup of 60 Mignot Napoleonic sets and a sampling of highly sought-after productions by Imperial, a New Zealand company that went out of business five years ago. Similarly, Zulu War sets by Welsh manufacturer Trophy are expected to find favor at auction. Trophy's production has scaled down, and older lines are becoming much more desirable now that they've been retired, Haradin noted.

Also poised to cross the auction block are East of India Samurai figures, Edmund's sets depicting Civil War regiments, many complete and with banners; and a large and diverse King & Country selection representing toy soldiers of every 20th and 21st century war, from World War I through the present-day Afghanistan War.

"There's so much more in this auction. My advice to collectors is to spend some time looking through the catalog. They're very likely to find things they've been looking for," Haradin said.

Old Toy Soldier's June 2-3 auction is an absentee, phone and Internet live bidding event that will commence at 10 a.m. Eastern Time on both days. Absentee bids, including those placed online via [www.LiveAuctioneers.com](http://www.LiveAuctioneers.com), must be made no later than 24 hours prior to the sale in order to be accepted. Phone lines must be reserved no later than 24 hours prior to the sale in order to bid by phone as the auction is in progress.



*Printed full-color catalogs are available for \$35 postpaid (overseas postage additional). View the fully illustrated electronic catalog and leave absentee bids online through [www.LiveAuctioneers.com](http://www.LiveAuctioneers.com). To order a printed catalog or to obtain condition reports or additional information on bidding, call Ray Haradin at 412-343-8733 (tollfree: 800-349-8009) or e-mail [raytoys@aol.com](mailto:raytoys@aol.com). Catalog mail orders should be addressed to: P.O. Box 13324, Pittsburgh, PA 15243. Additional sale details are available online at [www.oldtoysoldierauctions.com](http://www.oldtoysoldierauctions.com).*

*Trophy World War One Set No. EQ60 R.A. Mobile Field Howitzer, 7 Pieces with box Excellent Condition \$200-250. OTSA images.*



# AUCTION PREVIEW

## EXTREMELY RARE BOXED SET FROM A PREVIOUSLY UNRECORDED MANUFACTURER FOR SALE AT BONHAMS KNIGHTSBRIDGE 7 JUNE

'MADE AT The Sir William Treloars Cripples Centres, London', mounted 54 mm fixed-arm figures, a 2nd Life Guard and three Royal Horse Guards with three Fusiliers on foot in original box, label illustrating Sir William Treloar, patron Queen Alexandra and cripples (G 2nd Life Guard head loose, box F but label intact, two corners of lid and tray split) 1907 (7) £300-400

### HISTORICAL NOTE

Sir William Purdie Treloar was Lord Mayor of London when in 1907 he founded Treloars as a fund to aid cripples. In 1908 he founded his famous hospital in Alton, Hampshire, which has continued ever since as a leading provider of care for disabled young people. From the information on the lid of this box, it would seem that Sir William had set up 'Cripples Centres' in London prior to the opening of

the Alton Hospital, and that they were doing their bit to raise funds by manufacturing one of that period's most popular toys, hollowcast lead soldiers. This endeavor was doubtless quite fun and good therapy for the young participants. Another charity well known to supply toy soldiers at this time was 'Lord Roberts Workshops'.

The venture cannot have lasted long, since this is the first surviving box to come to auction, nor have any of the figures been seen before in the collector market. The Household Cavalry figures are nicely designed, and the aiguillettes are in the mould and painted. Most unusually, the Royal Horse Guard head is different from that of the Life Guard, with the former depicting a plume that is flowing back from its support in a way that makes it distinct from any other model of the helmet.

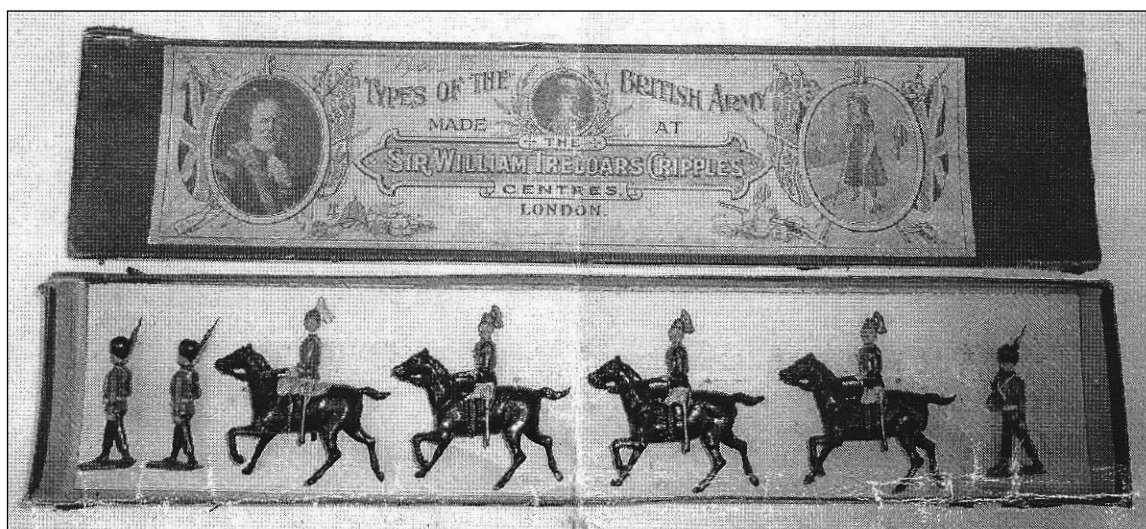

# AUCTION PREVIEW

## SHAMUS WADE TOY SOLDIER AND FIGURE AUCTION

*By Norman Joplin*

Special Auction Services - SAS in Newbury UK are to auction the Toy Soldier and Figure collection of the legendary Shamus O.D. Wade.

Toy Soldier dealer, collector, author and Instigator of the famous Nostalgia range of new toy soldiers in conjunction with Jan and Frank, Mr. Wade also amassed an amazing collection of toy soldiers and figures, many rare and some unique which will come under the hammer at SAS on June 15th.



Other features of the sale as well as Britains and Heyde ( see advertisement in this issue) are many examples of figures produced by Britains for the Mechanical Coronation Display of the 1950s. For collectors of other early manufacturers products ,John Hill, Fry, BMC, Reka, Hanks, Renvoize, Lord Roberts Memorial Workshop etc there is a multitude of items to consider. Civilians by Timpo, Taylor and Barret and Charbens are featured as well as a large collection of Plastic figures including those of minor manufacturers Trojan, Kentoys etc.

Included in the collection are examples of everything produced under the Nostalgia banner with the added bonus of additional items made into sets for Mr. Wade's personal collection.

Contact Hugo Marsh at SAS for more details.



Nostalgia



Britains figures from the Mechanical Coronation Procession



**SHAMUS WADE TOY SOLDIER AND FIGURE AUCTION (Cont.)**



Heyde

**SHAMUS WADE TOY SOLDIER AND FIGURE AUCTION (Cont.)**



Britains figures from the Mechanical Coronation Procession

*Photographs courtesy of Philip Dean*



# SAS

Est. 1991

specialauctionservices.com

## The Shamus Wade Toy and Model Figure Collection 15 June 2012



*Heyde 'Engl. Balloon Detachment No. 737'*

Special Auction Services is privileged to be offering for sale the figure collection of Shamus Wade, the renowned collector. He is also celebrated as the creator and designer of the famous Nostalgia range of toy soldiers and the auction includes his own reference collection of sets and multiples, probably the largest in existence. It also includes fine Britains military, civilian and Paris Office, Heyde, Haffner, Hill, Ping, Timpo, Authenticast, Mignot, Renvoize, Hanks, BMC, Wood, Reka, plastics and many others.

Contact: Hugo Marsh or Bob Leggett on 00 44 (0)1635 580595

81 New Greenham Park, Newbury RG19 6HW, Great Britain  
[toys@specialauctionservices.com](mailto:toys@specialauctionservices.com)

# Military, Civilian Figures, Equipment & Accessories

To be Auctioned by Vectis on **Tuesday 10th July 2012** at Thornaby, England

The second Vectis Military, Civilian Figures, Equipment & Accessories sale of 2012 will take place on **Tuesday 10th July**.

The Sale of around 800 lots will include comprehensive sections covering: Tinplate & Composition, Plastics, Modern Issues, Contemporary Makers, Civilian Issues, Other Makers, Books, Catalogues & Ephemera & Britains Military Ranges. Highlights will include: a comprehensive collection of Britain's Racing Colours which contains a number of rare American Colours, an exquisite selection of large scale Heyde Foot Knights, Britains "Soldiers that Shoot" - the very rare pre 1900 1st issues with sprung rifles, a fine Timpo early plastic issue large Waterloo Set containing the full range of British types and further items from the Charles Biggs Collection.



email - [simon.clarke@vectis.co.uk](mailto:simon.clarke@vectis.co.uk) for more details



AUCTIONS HELD ON-LINE IN ASSOCIATION WITH ARTFACT/INVALUABLE.COM



**Email - [admin@vectis.co.uk](mailto:admin@vectis.co.uk) Telephone - +44 1642 750616**  
Vectis Auctions, Fleck Way, Thornaby, Stockton-on-Tees, TS17 9JZ, England

www.vectis.co.uk

## The Stewart Saxe Collection of 1950s Toy Soldiers and Civilians, and other Fine Toy Soldiers

Thursday 7 June 2012  
Knightsbridge, London

**Bonhams**

1793



The Stewart Saxe collection of 14,000 figures contains over 300 rare boxed sets, many Mint, concentrating on Charbens, Cherilea, Crescent, Johillco, Timpo and other British makers of the 1950s. Also on offer, Treloar's Toy Soldiers 1907, Britains, Beiser, Aircraft, Mcloughlin, Marx Soldiers of Fortune, CBG Mignot, Ping, Courtenay, Greenhill, Composition and Heyde, with a No.2 size Children's Christmas Procession and Emperor Haile Selassie Lion Hunt.

For a free and confidential valuation with a view to selling at Bonhams or for further details regarding the auctions please contact:

+44 (0) 20 8963 2839  
[leigh.gotch@bonhams.com](mailto:leigh.gotch@bonhams.com)

+44 (0) 20 8963 2836  
[james.opie@bonhams.com](mailto:james.opie@bonhams.com)

Catalogues  
+44 (0) 1666 502200  
[subscriptions@bonhams.com](mailto:subscriptions@bonhams.com)

Or visit our web site three weeks prior to the sale for full catalogue descriptions and illustrations.

A very rare, Johillco M.G.M. Film 'Across the Wide Missouri' tie-in U.S. Cavalry Fort £600 - 800

International Auctioneers and Valuers - [bonhams.com/toys](http://bonhams.com/toys)



# SHOW REPORT

## 23RD ANNUAL WEST COASTER TOY SOLDIER AND MINIATURE FIGURE SHOW MARCH 11, 2012

As usual, several days prior to the Sunday, March 11th 2012, show, dealers arrived at the Irvine Marriott Hotel and set-up shop in their rooms. The traffic of collectors ebbed and flowed through the open doors of 42 rooms as bargains were found and deals struck. Saturday evening dealers faced the task of dismantling room displays and getting ready to move their wares into the first floor exhibit hall for the morning opening. The loss of an hour's sleep, because Daylight Saving Time would commence at 2 A.M. Sunday, did not seem of great concern.

Heralding the opening of the show at 9 A.M. Sunday, the skirl of bagpipes and the beat of a drum were heard as Woody Lambrith led a parade of re-enactors around the assembled dealer tables. Frank Cooper sang God Bless America and the doors were opened allowing the entry of the public.

The eager attendees found 71 dealers and 108 tables of figures and associated items. Vintage figures, both metal and plastic, were displayed. Many of these were mint in their original boxes. A multitude of loose figures

in various conditions were available. Contemporary manufacturers offered an extensive variety of their products including newly released figures. A wide selection of books was offered by two or three dealers. Kits and materials with which to create dioramas were available from several dealers.

In the hallway, outside the entry to the exhibit hall, the re-enactors set up displays of their equipment along with dioramas relating to their organizations. One of the displays featured a WWI Vickers machine gun which attracted much attention.

Craig McClain said "Despite the economy slowing the hobby; collectors were buying." A majority of dealers told him that sales were better and that it was a good show.

On a different note several regulars were not able to attend this year's show due to personal commitments or illness. Craig has heard from them and that they looked forward to next year's West Coaster.

*Photos by Noel Schlageter*



The dealer's room trading information.



Room Trading



Helen and Bob Bailey, Judi Ann and Bob O'Connor



Room Trading



Woody Pipes open the show



William Hocker

# SHOW REPORT

## THE SOUTH FLORIDA SHOW

*By Jack Matthews*

On Sunday, January 29 I attended the 18th Annual Florida Toy Soldier, Action Figure, Toy and Collectibles Show held at the very large Scottish Rite Masonic Hall right outside Lake Worth, Florida. I've been going to regional toy soldier shows since the first two were held by our DC Club and MFCA in Philadelphia. Back then, of course, the venues were jammed with antique soldiers, 1930's and 40's toys and all sorts of ephemera. Many of us old timers built our collections that way.

Recently and not surprisingly, with a few exceptions, most of the items offered at small shows are of the new variety, with many dealers showing King & Country, Conte, Frontline, New Britains, Russians and similar excellent products. In recent years, the antiques have shown up less and less. But the South Florida Show was an exception and a very pleasant surprise.

My wife and I are spending the winter months in beautiful Sarasota, Florida going from high up in the Great Smokies of North Carolina to beautiful Tampa Bay. When we arrived a few months ago, I was delighted to find that my old friend Jim Alexander had lived here for twenty years. Jim was a "snail mail" list dealer in composition figures over thirty years ago and now, like many of us, sells and buys on eBay. After having a great reunion with Jim and his son, Jim Jr., another avid collector, we took the easy three hour drive around Lake Okeechobee to Lake Worth.

Expecting the usual recent show offerings and attending mainly to renew some old hobby friendships, we were in for a very nice surprise. Arriving early afternoon the day before the Show, we found dealer setup well underway. Early Saturday evening we were all treated to a free sit-down dinner of home-made Italian sausage, cole slaw, potato salad and yummy desserts. Wow!

We spent a wonderful show day on Sunday amazed at the availability of old Britains, Dimestore, Heydes, many old toys and to my delight a bunch of the WWII "paper" cardboard cut-out and punchout sets that I collect. Frankly, I haven't seen any at a regional show in years. I went home with a large MIB set of cutouts by Saalfeld at a very low price, several Saalfeld Mint Punch out soldier and sailor booklets from seller Steven Smiles, a box for the large pre-war colorful Marx Sparkling Doughboy Tank and two boxed sets of WWII Air Recognition Models.

Alan Kelsey, one of the great model makers in the hobby had a table full of his marvelous creations, offered at terrific prices. I bought three. Alan had a marvelous 54mm WWII English Pub building with a removable roof and figures inside for sale. I was very tempted.

When I asked John Lesinski, Show Co-chairman about the show's low prices for such older treasures, he opined that many of the large club's members, like all of us who are aging, were culling out their treasures.

Many older readers will recall John's now-rare solidcast early German and US dreadnaughts, Indian Elephant Mountain Battery and other items sold at the Widener and Valley Forge MFCA Shows. Just a few of each were made, and if you didn't get to his table by 8:30am during setup, you were out of luck. John's prize creation this year was the 40mm Boxer Rebellion semi-round diorama. I bought it on sight, beating my friend, former Federal Judge Tom Scott to the punch.

Hobby Bunker had several tables filled with its usual goodies as did regional show dealer Hank Horn, Alan Gwin who has been doing this for years had many tables of older goodies. I snapped up a great New Era Dimestore German Band conversion from him for five bucks each.

New to me was the very affable owner of Crown Toy Soldiers who had several tables of marvelous offerings, including a large Western Stagecoach. I bought three of his Spanish-made Blackhawk medieval knights. I plan on ordering more through his website, [www.crowntoysoldiers.com](http://www.crowntoysoldiers.com)

Figures entered by Club Members in the painting competition were less than one usually sees but were of excellent workmanship. Curtis Slight, Club Historian, collector, painter and long-time hobby writer displayed a neat piece.

At 130 tables and fifty dealers, this is a large regional show. The Club went out of its way to make everyone feel welcome. Where else can you get a free, tasty pre-show "Appreciation Dinner", catered by Tony Angecara, Show Founder and Chef? The Club's co-chairmen Mike Skurda and John Lesinski are to be congratulated on putting on a fine weekend. While South Florida is a bit off the Toy Soldier trail, it's a great way for "snowbirds" to sneak in a hobby "fix" during a sunny mid-winter vacation.



# SHOW REPORT (Cont.)



Tony Angelora, Show Founder and John Lesinski, Co-Chair of the Show



Views of the Displays



Views of the Displays



Views of the Displays



Curtis Sleight



Alan Kelsey



Mike Skurda - President and Co-Chair



# SHOW REPORT

## INDY TOY SOLDIER SHOW

*By Barry Carter*

This years Indy Toy Soldier Show has moved to a new location on the east side of Indianapolis at the newly renovated Marriott East Hotel. We enjoyed the benefits of having a hotel familiar with the concept of trade shows and room trade having hosted many different collector clubs over the past thirty years. So how did it work for us? All of the trading rooms (50 available) were located on the first floor, many had access thru their patio to the parking lot so it was easy loading into the rooms. Moving from the trading room to the show room was expedited by all rooms-- show and trade being on the same floor and yes there were bell hops and carts available, but the rooms were so close that most moved themselves.

For moving in and loading out after the show the ball room offered seven entrances for the move.

The show opened to a brisk crowd, Attendance was approximately 375 not counting children admitted free and continued steady up until 1:30 to 2:00. Comments received from the dealers were Enjoyable Show, Good Room Trade, Good sales, Great Room, No crowding, Great Lighting, Great Hotel Hospitality, Easy to get to, Easy to get their customers in, and again good sales. The mix in the show was approx 65 % plastic and play sets to 35% in metal, composition, books and others. We had dealers come in from as far as Texas and New Hampshire. All in all we had dealers from 20 states.



Don Pielin, Bob Hornung, Steve Sommers



Bill Graver, Joe Wallis



Nick Albanese



Gail and Tony Teper and Michael Mattimore



Sue and Gary Miller



Show Venue



# Ohio Toy Soldier Show & Sale™

## Our 20th Great Year!

- Antique to Modern Toy Soldiers & Equipment
- Metal, Plastic and Composition Soldiers
- Something for Everyone...  
Beginner to Advanced Collector
- Quality Dealers from  
Around the Country

**Sunday , May 20, 2012**  
**The Galaxy Restaurant**  
**201 Park Centre Dr.**  
**Wadsworth, Ohio**  
**St. Rt. 94 & 176**  
**10AM-3PM**

For more information, contact:  
 Doug McClure  
 412 E. Liberty St.  
 Medina, Ohio 44256  
 Tel: (330) 722-6751  
 E-mail: dmccclure1@zoominternet.net



## TOY SOLDIERS ETCETERA



## Dimestore Soldiers

*Over 20 years of buying & Selling  
 Barclay, Manoil, Grey Iron,  
 & other dimestores & accessories*

**We issue 3 to 4 mail order catalogs a year of 500 to  
 600 top quality figures & vehicles**

Send SASE for next catalog to:  
 Stan & Sally Alekna  
 732 Aspen Lane; Lebanon, PA 17042-9073  
 Phone: (717) 228-2361  
 E-mail: salekna1936@yahoo.com

**THE  
 TOY SOLDIER SHOP  
 OF WASHINGTON, D.C.  
 503 11<sup>TH</sup> STREET, S.E.  
 WASHINGTON, D.C. 20003**

Specializing in the conversion of  
 your old Britains figures,  
 to your instruction; including color  
 parties, bands, artillery teams, etc.

**~ALL PAINTED TO THE  
 HIGHEST STANDARD~**

offering  
 toy soldiers  
 old and new

always  
 buying  
 collections



Neil Rhodes

Proprietor

202 546 2201

**TOYSOLDIERSHOP.COM**

# Now Available

## BRITAINS CIVILIAN TOY FIGURES

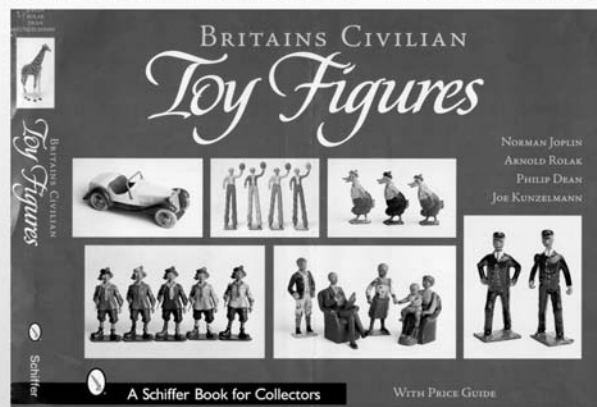

Norman Joplin, in association with Arnold Rolak, Philip Dean and Joseph Kunzelmann

Concentrating on Britains products of a non-military nature produced between 1880 and 1966, this all color book has eleven hundred plus photographs and covers every aspect of civilian and non-military figures.

Farm, Zoo, Circus, Garden, Racehorses, Sports, Railway, Civilian Vehicles, Footballers, Lilliput and Cococubs, including color variants never before illustrated.

Order from:

Norman Joplin, 535 Fir Street, Fredonia, WI 53021  
 Telephone: 262.692.3913 • Email: info@normanjoplin.com  
 Make checks to Norman Joplin. • \$49.95 + \$3.05 (S/H - within USA) = \$53.00

**Joseph Saine Toy Soldiers Presents:**



# **Toy Soldier Extravaganza**

## **July 21 & 22, 2012**

Holiday Inn Livonia Michigan  
I-275 & 6 Mile Rd 48152

**Toy Soldier Auction Saturday, July 21 1 p.m.**

300+ lots of Toy Soldiers sold at no reserve

**Toy Soldier Show Sunday, July 22 10 a.m.**

100 tables of Toy soldiers  
with Dealers from over 10 states

Also featuring room trading Friday and Saturday



*"Nothing like a two-day pass!"*

**For Auction Consignment & Table Information, contact:**

Joseph Saine Toy Soldiers  
628 Dixie Highway  
Rossford, OH 43460  
419.662.8697  
email: [jos@josephsaine.com](mailto:jos@josephsaine.com)



# NORMAN JOPLIN'S OLD TOY SOLDIER and FIGURE SHOW (UK) SATURDAY 8th OF SEPTEMBER 2012

**Holiday Inn London - Bloomsbury**  
**Coram Street, London**  
**WC1N 1HT**

**The Turner and Booker Suites**

*(Only 2 minutes walk north of Russell Square  
Underground Station and 1 minute east of the  
Royal National Hotel)*

## **ADMISSION £3**

*Entry to the PUBLIC - 10:30 AM - 4:00 PM*

*Early Bird entry from 6:30 AM - £ 15*

**For further  
details contact:**

**Adrian Little**

Telephone: 01635-30535

e-mail: [info@mercatortrading.com](mailto:info@mercatortrading.com)

Norman Joplin (USA)

Telephone: 001-262-692-3913

e-mail: [info@normanjoplin.com](mailto:info@normanjoplin.com)



**Show Sponsored By  
Old Toy Soldier Magazine  
and Old Toy Soldier  
Auctions USA**



**This is a dateline show for old toy soldiers and figures, pre 1980 vintage**

# OTSN's 32<sup>nd</sup> CHICAGO TOY SOLDIER SHOW

**Sunday, September 23, 2012**

10 am to 3:30 pm

\$8 Admission

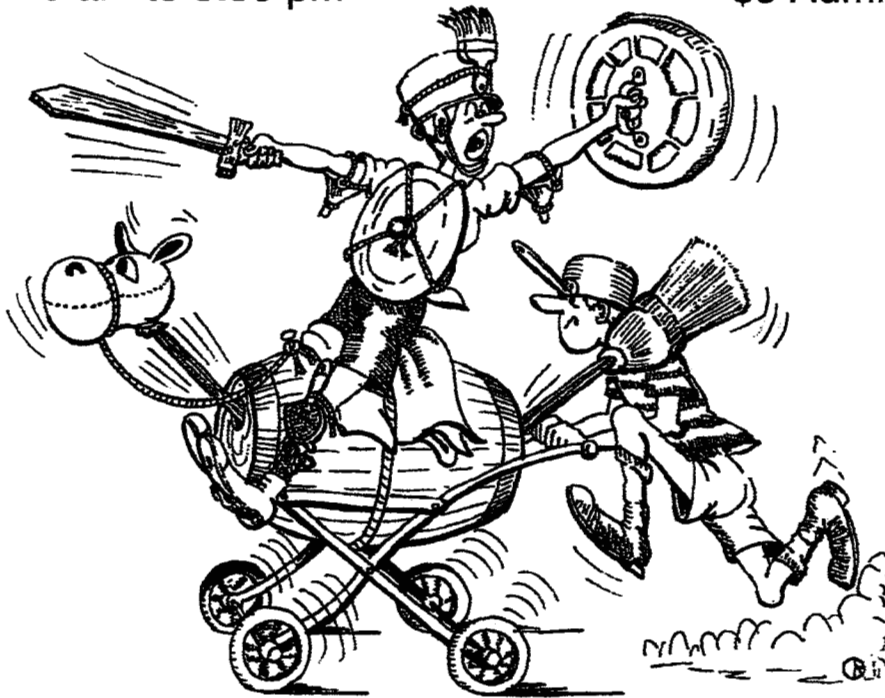

***On to Chicago! Charge!***

**Soldiers, Farm, Circus and Zoo, Old and New Figures**

Hyatt Regency Woodfield

1800 East Golf Road, Schaumburg, Illinois

847-605-1234

**Show Information: Don Pielin**

106 Cottonwood; Streamwood, IL 60107

630-497-1239 email: [dimestores@aol.com](mailto:dimestores@aol.com)

Dealer Information and more: [www.toysoldiershow.com](http://www.toysoldiershow.com)

On Facebook visit **Chicago Toy Soldier Show**



Celebrating 30 Years of Great Toy Soldier Shows  
**30th Annual East Coast  
Toy Soldier Show & Sale**

Also featuring a vast array of antique & collectible toys and more!!!

**Sunday, November 4, 2012**

**9 AM – 3PM**

Wide  Handicap  
Aisles **ROTHMAN CENTER** Accessible  
A non-smoking facility

FAIRLEIGH DICKINSON UNIVERSITY  
Hackensack, NJ

From Route 4, Hackensack Ave., south exit, then left at  
2nd light (Temple Ave.); to Rothman Center.  
Six miles west of George Washington Bridge, off of  
Route 4 West Hackensack Ave

CELEBRATING 30 YEARS OF  
GREAT TOY SOLDIER SHOWS

Millions of Antique & Collectible Toy  
Soldiers Military Miniatures • Miniature  
Civilian Figures • Railroad • Christmas  
• Zoo • Farm • Diecast • G.I. Joe &  
Action Figures • Militaria • Over 300  
Vendor Tables of Antique and  
Collectible Toys

**IT'S THE LARGEST SHOW  
OF ITS KIND**

*with Over 300 Exhibitor Tables  
and Convenient Free Parking*

**ADMISSIONS**

**Adult: \$6.00**

**Children under 12: FREE**

**SPONSORED BY: Vintage Castings**

**Tel: (973) 831-8900 • Fax: (973) 831-8912**

Want to make money at the show  
and not just spend it? Become a  
vendor!

**Email: [bill@vintagecastings.com](mailto:bill@vintagecastings.com)  
[www.vintagecastings.com](http://www.vintagecastings.com)**

*Coming Soon: [www.eastcoasttoysoldiershow.com](http://www.eastcoasttoysoldiershow.com)*

★ *Prepaid ticket option. Save time. Purchase your ticket by mail.*

*Hand ticket to ticket-taker & enter through separate prepaid admissions door at 9AM.*

*This allows for no waiting at general admission box office.*

Please reserve me \_\_\_\_\_ prepaid admission ticket(s) at \$6.00 each.

Mail checks payable to: **Vintage Castings, P.O. Box 4809, Wayne, NJ 07474-4809**

Print Name: \_\_\_\_\_ Phone Number: (\_\_\_\_) \_\_\_\_\_

Address: \_\_\_\_\_ City: \_\_\_\_\_ State: \_\_\_\_\_ Zip: \_\_\_\_\_

Note: A self-addressed Stamped Envelope must be sent for prepaid tickets.

Be sure to set aside Sunday, November 4, 2012. Remember to bring your tickets. No Refunds

**HISTORY COMES ALIVE AT THE EAST COAST TOY SOLDIER SHOW AND SALE.**

[vintagecastings.com](http://vintagecastings.com)

MEMBER OF  
Professional Show Manager's  
**PSMA**  
Association, Inc.

# 2013 24th Annual West Coaster

Toy Soldier & Miniature Figure Show

Sunday, March 10  
9 a.m. - 3 p.m.

FREE ROOM ACTIVITY  
ON THURSDAY THRU SATURDAY.  
OPEN TO PUBLIC.  
COME SEE THE DISPLAYS  
IN THE HOTEL ROOMS!

## IRVINE MARRIOTT HOTEL

Featuring Antique Britains, Dimestore, Composition & Plastic,  
Military & Civilian Figures and Sets. An international gathering of  
leading Manufacturers, Dealers and Collectors.

FOR TABLE INFORMATION:  
PHONE (760) 758-5481, FAX (760) 758-7004

**Admission \$6, under 12 is free**

**IRVINE MARRIOTT HOTEL**  
18000 VON KARMAN AVE. • IRVINE, CA 92612  
CLOSE TO ORANGE COUNTY AIRPORT  
1-800-228-9290 • HOTEL DIRECT (949) 553-0100



# Your one-stop shop.

Toy soldiers-new or old, plastic or metal, assembled or kit. Rare finds from shows and trades. Finishing supplies, diorama & scenery accessories, military books & magazines.



Thomas Gunn Miniatures  
#55001A 7.5cm Gun &  
3-Man SS Crew \$120.00



Paragon Scenics P5001FB  
U.S. Cavalry Set #1 \$17.00



US Marines Take a Breath  
Figarti A4058 ~~\$89.00~~ \$71.20

W.Britains 36041  
Scots Grey Guidon Bearer  
& Gordon Highlander  
\$120.00



Marx PL-224G Military  
Barracks - Army, Gray,  
Hard Plastic \$15.00



John Jenkins Designs  
#JR-17 Highlander &  
British Line Infantry  
\$68.00



King & Country CW052(SL)  
President Abraham Lincoln  
& His Generals  
\$129.00



W.Britains 31057  
Union Cavalry Corporal  
Dismounted, Firing Pistol  
\$25.00



**A store, a website, a travelling show!!**

**OUR STORE:** Our 7,000 sq. ft. store is located at 33 Exchange Street, Malden, MA near the Orange Line Malden Center 'T' (subway) stop. We're just 10 minutes north of Boston, off Route I-93. Store Hours: Mon-Sat 10-6, Thurs until 8pm, Sun 12-5pm

**TO PLACE AN ORDER:**

**By Phone:** 1-781-321-8855

Phones are manned from 9:30-6:30, Mon-Fri, Sat 10-6, Sun 12-5

**By fax:** 1-781-321-8866

**By mail:** Send your order to

Hobby Bunker, Inc., 33 Exchange Street, Malden, MA 02148

check our sale section and weekly specials!

**Free Shipping**  
on all orders \$75  
or more (domestic,  
until further notice)

**Online:** [www.hobbybunker.com](http://www.hobbybunker.com)

## ❖ Rodden Heraldic Sculpture ❖

Custom Made Portrayals of Medieval Knights in  
50mm, 54mm and 90mm Scales

Your Choice of Pose and Coat of Arms



Ferry De Lorraine Count of Vaudemont  
Agincourt 1413  
50mm Scale



Robert Stewart of Ralston  
50mm Scale



Otto Graf Von Langenberg  
50mm Scale

**Each Figure Signed and Dated by Brian Rodden**

---

*For More Information Contact:*  
Rodden Heraldic Sculpture , 142 Sligo Road, Rollinsford,  
N.H. 03869. Tel and Fax 603-742-7480





**Mignot**

**GUY  
RENAUD  
FLAGS**

**L C  
Lucotte**



the **ONLY** Authorized Distributors for the Americas  
*Greatest Selection in the Entire World*

We stock the Book and virtually  
**EVERYTHING** in it

Call for an appointment  
to visit our SHOWROOM... we always buy  
CBG Mignot, Lucotte, & French flags.

## Le Petit Soldat

Jack Carleton

14 Ridgetop Drive, St. Louis, MO 63117-1021  
Tel: 314-567-3311 • 866-862-3311 • Fax: 314-567-3314

Email: jcarleton@aol.com

Come Surf Our Web Page: [www.lepetitsoldat.com](http://www.lepetitsoldat.com)

King & Country • Monarch Regalia • ART.IG • Rodden Historical

# Green's Collectables

## Toy Soldiers At Their Best

### TIME PERIODS OFFERED

Greek Hoplite, Persian Inf., Persian Immortals  
Scythian Archers, Imperial Standards  
Persian Army and Mercenaries.  
Samurai, Army of Oda Nobunaga, Shogun  
French & Indian War, American Rev. War  
Plains and Northwest Coast Indians,  
Napoleonic, War of 1812,  
Boxer Rebellion (China), Crimean War  
American Civil War, Indian Mutiny (India)  
Zulu War, Durbar Parade (India) 1900  
WWI, WWII, V-Nam, Highland Life  
French Foreign Legion, Victorian  
Present day combatants  
Bands from all time periods, Holiday sets

### OUR MAKERS

Alexander Toy Soldiers  
Beau Geste, Britains, Dorset  
East Of India, Rosedale  
Frontline, Fusilier, GBE  
Little Lead Soldier  
Larson Toys, Alymer  
Marlborough, PNF  
RP World Models/Steadfast  
Tommy Atkins, Oryon  
Leddy & Slack  
Wilson Edwards  
JG Miniatures  
Prince August Molds  
Forward March  
Irregular Miniatures  
Thomas Gunn Miniatures

[www.greencollectables.com](http://www.greencollectables.com) • [algreen@greencollectables.com](mailto:algreen@greencollectables.com)

46 Warren Trail, Denville, NJ 07834 973-627-4961

# ABOVE THE BATTLEFIELD PART I: PRE-1918 GERMAN-MADE AIRSHIP SETS

By Earl Jorgensen

In the early afternoon of Nov. 21, 1783, two human passengers were lifted high above Paris in a wicker basket dangling beneath a huge balloon filled with hot smoke. Once airborne they set about feeding bundles of straw into an onboard fire pit (which prevented the smoke from cooling) and applying wet sponges to the flaming embers landing on the balloon's surface. The balloon was the latest experiment conducted by Joseph-Michel and Jacques-Etienne Montgolfier, brothers obsessed with the dream of human flight. The 25 minute flight covered a distance of nine kilometers before returning its soot-covered "aeronauts" to the earth. Among those witnessing the event was Benjamin Franklin who later referred to the flight as "a discovery of great importance. . . . Convincing sovereigns of the folly of wars may perhaps be one effect of it."<sup>1</sup>

France established the world's first air force, the *Compagnie d' Aerostiers*, on Apr. 2, 1794. On the morning of June 26, the French commander, Gen. Marlot, ascended high above the battlefield of

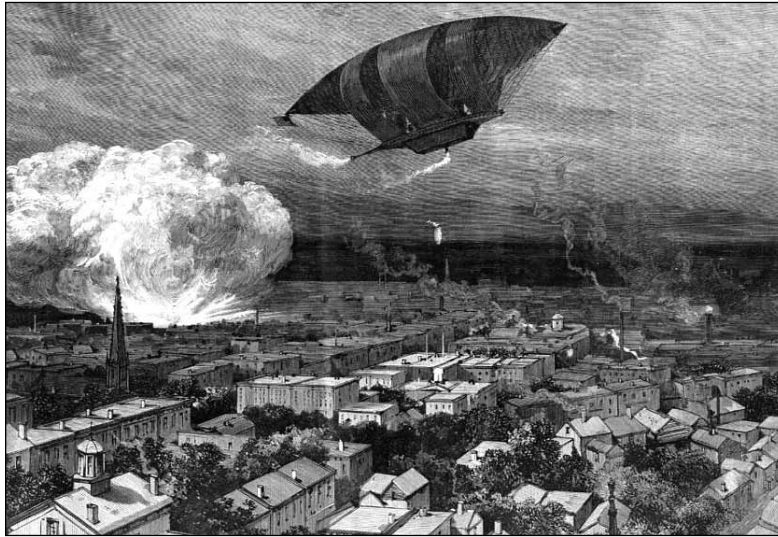

A period illustration of a dynamite dirigible from a May, 1885 issue of *Harpers Weekly*. Fueled by the imagination of early science fiction writers, the public was both fascinated and fearful of destruction from the sky. In 1899, the Hague Peace Conference declared the dropping of explosives from balloons as unlawful. (Wikimedia Commons)



An early representation of an observation balloon by an undetermined maker. The balloon is connected to its base by a wire spring and would vibrate at the slightest touch, producing a sense of motion.

Fleures aboard the *Compagnie's* balloon *L'Entreprenant*. He remained airborne for the duration of the battle, carefully observing the deployment of the Austrian forces and redeploying his troops to counter their movements with orders which were dropped to the ground attached to sandbags. While the defeated Austrians accused the French of violating the rules of war, the French acknowledged the important role the balloon played in the victory, comparing an army without a balloon to a "duelist fighting blindfolded."<sup>2</sup> The *Compagnie* was quickly expanded and, in 1797, several balloon units



A decorative panel from a J.G. Rupprecht box label, c. 1906. The observation balloon in action over an 18th century battlefield likely represents the French *Compagnie d' Aerostiers* during the Battle of Fleures in 1794. (photo by author)



An early flat *Drachen* style observation balloon cabled to a hand-cranked winch mounted on a wagon attributed to Johann Haffner. The *Drachen* (kite or dragon) balloon was introduced by Germany in 1896. (photo courtesy of Bernhard Schwarz)

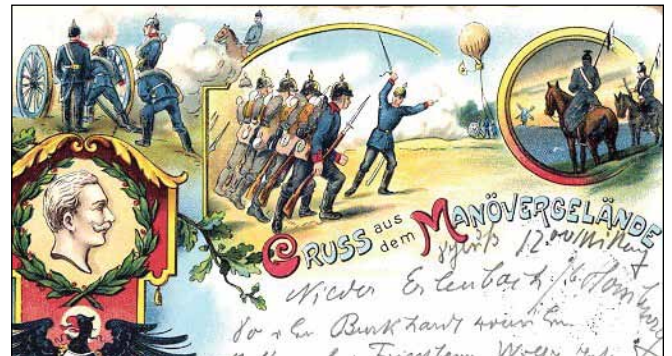

A period postcard commemorating the 1897 German Autumn Military Maneuvers which utilized military observation balloons. The maneuvers were often referred to as the Kaiser-Maneuvers, a nickname based on the traditional cavalry charge personally led by the Kaiser to conclude the event. (author's collection)



## ABOVE THE BATTLEFIELD (Cont.)

accompanied Napoleon to Egypt during his Nile Campaign. As fate would have it, the transport ship carrying their equipment was sunk by the British before it could be off-loaded and, upon his return to Paris in 1799, Napoleon ordered the unit disbanded. Observation balloons would not be deployed over another battlefield until the American Civil War.

In June of 1861, Professor Thaddeus Lowe was appointed Chief Aeronaut of the newly formed Union Army Balloon Corps, a civilian aeronautical unit attached to the Army of the Potomac. The unit served with distinction throughout McClellan's Peninsula Campaign of 1862, providing valuable intelligence, directing artillery fire and even conducting experiments with air-to-ground telegraph communications. On Nov. 7, 1862, McClellan was replaced by Gen. Burnside who preferred to rely on the traditional "eyes on the ground" intelligence provided by the cavalry. Thaddeus Lowe, often referred to as the "most shot at man in the Civil War,"<sup>3</sup> resigned his post in April, 1863, and the Union Army Balloon Corps was officially disbanded a few months later.

Burnside's failure to recognize the potential of military observation balloons was not shared by his European counterparts. France re-established its military aeronautical corps in 1877 and was quickly followed by Germany in 1884. Great Britain acquired its first balloon in 1879. Ironically, it was originally produced for the Union Army Balloon Corps by none other than Professor Thaddeus Lowe.

Military interest in aeronautics was not, however, limited to the observation balloon. In the mid-19th century, a new type of balloon with the potential capability of navigating through the sky under its own power was introduced. The craft was referred to as the dirigible balloon. Unlike observation balloons which either drifted with the wind or were held in place by cables connected to the ground, dirigibles were equipped with rudders for steering and onboard engines to power the craft through the sky.

The first dirigible flight took place on Sept. 24, 1852, in a craft powered by a small coal-fired steam engine. The craft successfully flew a 17 mile course in slightly over three hours but strong headwinds forced the return flight to be cancelled. Controlled powered flight or the ability to fly against the wind was finally achieved in 1884 by the *La France*, a battery powered dirigible. In 1887, a dirigible powered by a gasoline fueled internal combustion gasoline engine designed by Gottlieb Daimler was successfully tested. Daimler patented his engine design and started commercial



A commemorative illustration depicting the *Compagnie d'Aerostiers* moving their balloon to the battlefield at Fleures in 1794. (Wikimedia Commons)

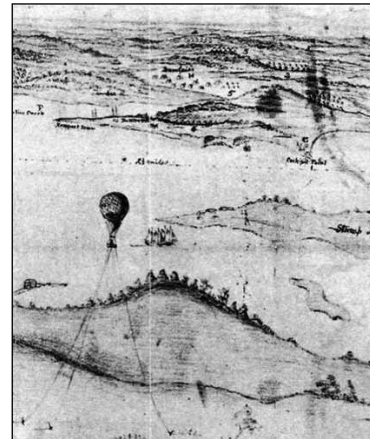

A battlefield sketch depicting Professor Lowe in the balloon "Constitution" during the Peninsula Campaign of April, 1862. (Wikimedia Commons)



A period illustration depicting Prussian lancers chasing a French balloon. During the 1870 Siege of Paris, the besieged Parisians built and launched a total of 68 such balloons to transport both mail and passengers out of the city. In spite of Prussian attempts to destroy the balloons, 58 balloons successfully carried 102 people, 5 dogs and over 2 million pieces of mail to safety. (Wikimedia Commons)

## ABOVE THE BATTLEFIELD (Cont.)

### Luftschiffer-Abteilung (Airship Battalion)

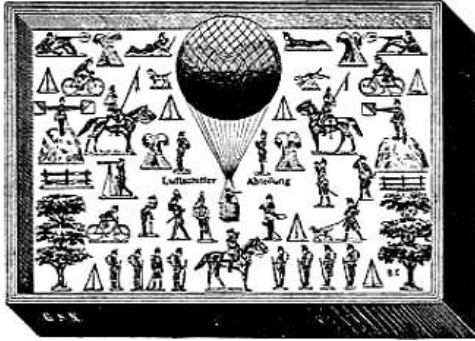

An illustration of a Spenkuch *Luftschiffer-Abteilung* (Aeronaut Department) set offered in the 1908 toy catalog of A. Wahnschaffe of Nuremberg. Since the balloon does not appear to be equipped with any type of a device for suspension or to create a sense of motion, it is likely a flat tin representation included to enhance the presentation of the set. ([www.zinnfiguren-bleifiguren.com](http://www.zinnfiguren-bleifiguren.com))

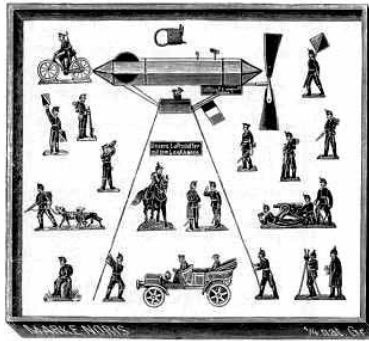

An illustration of a Gebr. Heinrich (Noris) clockwork powered Airship Battalion set offered in the 1910 catalog of Ullmann & Engelmann. The catalog includes an English subtitle of Aerial Navigation and identifies the figures as 52mm. ([www.zinnfiguren-bleifiguren.com](http://www.zinnfiguren-bleifiguren.com))



An illustration of a Spenkuch Zeppelin set offered in the 1910 Ullmann & Engelmann catalog. When connected to the clockwork powered roundabout base, the Zeppelin would "fly" in a circular pattern. Germany's first military zeppelin was introduced during the Autumn Military Maneuvers of 1909. The figures are listed as 52mm. ([www.zinnfiguren-bleifiguren.com](http://www.zinnfiguren-bleifiguren.com))

production. In spite of the fact that dirigibles were undependable, prone to catch fire and occasionally known to collapse mid-flight, they were quickly adapted for military use.

On July 2, 1900, Count Ferdinand von Zeppelin introduced a revolutionary new dirigible design. The 420 ft. craft utilized a rigid internal aluminum support structure enclosing seventeen hydrogen gas cells. Although his first design, designated LZ-1, was declared "unsuitable for neither military or civilian purposes"<sup>4</sup> by a government commission, von Zeppelin persevered, finally achieving success with his third design, designated LZ-3, in 1907. The craft was purchased by the German military in 1908 and used for training.

While the details surrounding the first German-made *Luftschiffer-Abteilung* (Airship Battalion) set of toy soldiers remain elusive, the industry-wide standard of producing sets that were "almost as up to date as contemporary newspapers"<sup>5</sup> would indicate that it was assembled shortly after the military established its first airship units. The earliest reference to an airship set I was able to locate was a "Balloon section, complete with wagons, bicycles, trees, etc."<sup>6</sup> offered in a 1902 mail-order catalog from the British firm of A.W. Gamage, Ltd. The fact that the description includes a bicycle offers an additional tool for dating the set. Germany was known to have first experimented with possible military applications of the bicycle during the Autumn Military Maneuvers of 1891,<sup>7</sup> providing the earliest possible production date for the set.

Additional information can be gleaned from published photos of surviving *Luftschiffer-Abteilung* sets and illustrations of sets offered in turn-of-the-century toy catalogs. It appears that the *Luftschiffer* designation was utilized throughout the industry for all types of balloon sets, including dirigibles and zeppelins. It also appears that the majority of dirigibles and zeppelins offered in the sets were equipped with ceiling hooks and rudimentary drive mechanisms designed to produce motion, characteristics normally associated with tin toys. German companies such as Marklin, Bing and Meier produced toys from shapes stamped out of thin sheets of tin-plate, bent into shape and held together with tabs. The toys were often equipped with either simple string wound motors or more technical clockwork-driven motors. Inexpensive, mass-produced tin toy dirigibles and zeppelins would "rise up and down on pulleys and string, their propellers turning as they did so."<sup>8</sup> Much as Heyde-made sailors enhanced warships made by Bing and Marklin-made brass cannons enhanced large scale field artillery units made by Heyde, the movement and motion provided by simple tin toys enhanced the appeal of the *Luftschiffer-Abteilung* sets of toy soldiers.

The airship sets were supported by assorted figures representing a variety of military personnel which often appear to be selected at random. Historically, military dirigibles did not become fully operational until 1908. Sets produced prior to that date basically represent a group of soldiers guarding and/or watching an airship while sets produced after the date began to represent an actual military supporting



## ABOVE THE BATTLEFIELD (Cont.)

the airship. Figures representing communications (often in the form of signal flags), mounted couriers (which were replaced by bicycles and motorcycles) along with officers observing through oversized telescopes (later replaced by binoculars) are present in all sets. Later sets introduced figures of mechanics (with oilcans and large fuel containers) and members of the flight crew wearing warm flight jackets. Additional figures of lancers, machine-gunners and assorted riflemen were often included as was an assortment of scenery (trees, shrubs and wheat sheaves) and equipment such as wagons, motorized vehicles and tents. Since sets could easily be expanded by simply adding additional scenery and equipment, they often were quite elaborate as seen in the following description of the *Luftschiffer-Abteilung No 737* set by Georg Heyde. "A tin Zeppelin capable of carrying four miniature crew members, eighteen ground figures as well as two cyclists and five hedges and trees. The airship was movable by a propeller. In addition there was both a station of carrier-pigeons and a signal-flag service."<sup>9</sup> One can only wonder what additional *Luftschiffer* sets may have been produced had the world not gone to war in the late Summer of 1914.

The war both isolated German toy soldier manufacturers from



A typical example of a *zinnfiguren* flight set with balloons, dirigibles, zeppelins and what appears to be a Wright Flyer by an undetermined maker, c. 1908.



An early representation of a dirigible balloon by an undetermined maker. Note the oversized rudder and the anchor.

their highly profitable export markets and severely limited the industries access to raw materials. Since toy soldiers were thought to promote the development of virtues such as national pride, love of country and patriotism in children, the German toy soldier industry was given access to sufficient raw materials to continue a limited production of sets designed specifically to reinforce the public's support for the war effort. A listing found in the 1915 catalog for the firm on Leipziger Lehrmittelanstalt von Dr. Oskar Schneider of Leipzig describes a *Luftschiffer-Abteilung* set which includes both a clockwork zeppelin-airship along with an automobile, an airship troop, a General Stall officer, a 14 figure military unit and assorted scenery.

### A Penny Toy Connection

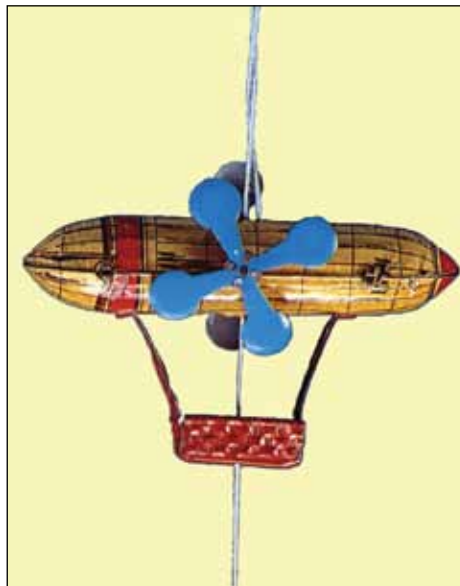

An inexpensive penny toy string operated airship produced by the firm of J. Ph. Meier, Nuremberg. (photo courtesy of J. Grimmer)



An Airship Battalion set from the firm of J. G. Rupprecht. A Meier string operated penny toy airship is clearly identifiable in the set. (photo courtesy of Gisbert Freber)



A partial Airship Battalion set from the firm of Georg Spenkuch. While the airship has lost its string in past combat, it also is identifiable as the Meier string operated airship. (photo courtesy of Gisbert Freber)



A Meier string operated airship photo showing the original string assembly. (photo courtesy of Gisbert Freber)

## ABOVE THE BATTLEFIELD (Cont.)



The destruction of a zeppelin. Although military aircraft were unarmed at the start of the war, a French pilot successfully destroyed a zeppelin by flying above it and dropping grenades. (author's collection)

A 1908 magazine advertisement from the firm of A. Wahnschaffe of Nuremberg, promoting their selection of aviation themed toys including a Spenkuch Airship Battalion set. The presence of a clockwork toy Wright Flyer is also of interest. ([www.zinnfiguren-bleifiguren.com](http://www.zinnfiguren-bleifiguren.com))

World War I gave the world its first opportunity to observe and evaluate the military effectiveness of the airship. Observation balloons were deployed in great numbers by both sides and once again proved their ability to direct artillery fire with the same deadly accuracy previously demonstrated in the American Civil War. France and Great Britain quickly realized that their small fleets of semi-rigid dirigibles were far too slow and vulnerable to be deployed as offensive weapons and quickly re-assigned them to naval operations where they excelled in anti-submarine warfare. Germany first introduced its new military zeppelin during the annual military maneuvers of 1909. Included in the demonstration was a scripted encounter between an airplane and the zeppelin. The underpowered airplane was unable to reach the altitude of the zeppelin, thus proving that the airplane was unsuitable for military purposes and that the zeppelin not only provided the capability of long range aerial reconnaissance and strategic aerial bombing, but was seemingly invincible.

Although German zeppelins did achieve some success early in the war, advancements in anti-aircraft weapons and the introduction of incendiary ammunition fired from the machine-guns of high flying airplanes soon drove them from the sky. By late 1916, surviving zeppelins were withdrawn from offensive duties and were replaced by large, multi-engine aircraft designated as bombers and, in the end, the battlefield was lifted into the sky on the wings of the airplane.



Although observation balloons were heavily defended by both anti-aircraft guns and military aircraft, they remained very tempting targets. Some pilots specialized in "balloon busting". (Wikimedia Commons)

1 *Modern History Sourcebook*: Benjamin Franklin: Experiments with Balloons, 1783 ([www.fordham.edu](http://www.fordham.edu)).  
 2 Johnson, Donald. *The Aeronauts* (Time Life Books, Alexandria, VA, 1980) p. 80  
 3 Sandburg, Carl. *Abraham Lincoln The War Years* (Harcourt, Bruce & Co., New York, 1939)  
 4 Botting, Douglas. *The Giant Airships* (Time-Life Books, Alexandria, VA, 1982) p. 17  
 5 Mannack, Thomas. *The Ancient World in Miniature: Tin Figures of the 19th & 20th Centuries*. University of Oxford, Beazley Archive.  
 6 *Mr. Gamage's Great Toy Bazaar 1902-1906* (Denys Imgram Publishers, London, 1982) p. 59  
 7 *Motor Vehicles in War* (New York Times, Sept 28, 1901)  
 8 Pressland, David. *The Art of the Tin Toy* (Crown Publishers, Inc., New York, NY, 1976) p. 125  
 9 Roer, Hans Henning. *Old German Toy Soldiers* (Palagonia Verlag, 1993) p. 27



# LIL ARMY MOLDS

Cast your own metal figures in 54 mm (1:32 scale) from high quality, vulcanized rubber molds.

Cast hundreds of figures from each mold and create your own dioramas with the figures.

Men, horses, equipment - everything needed to bring the history of our great country to life!



## TALIBAN

\$13.99 each

- LA-8150 Taliban Leader
- LA-8151 Junior Taliban Leader
- LA-8152 Taliban standing firing AK-47
- LA-8153 Taliban kneeling, firing AK-47
- LA-8154 Taliban throwing grenade

All LIL ARMY molds are also available as pre-cast, ready to assemble and paint kits in our MILL'S MEN line.

Each individual figure is \$8.00.

We also carry a full line of painted toy soldiers including Black Hawk, W. Britains, Collectors Showcase, East of India, Forces of Valor, Frontline Figures, King & Country, Marlborough and Tradition of London.

See all our figures on our website: [www.dutkins.com](http://www.dutkins.com)  
or in our Painted Toy Soldiers catalog for only \$8.00



Black Hawk Britains



Collectors Showcase



King & Country



Tradition of London

### Shipping Charges:

For UPS in the continental USA (No PO Boxes):

- \$10.00 for orders up to \$50;
- \$11.00 for orders of \$51-\$200;
- \$12.00 for orders of \$201-\$300;
- \$15.00 for orders over \$300.

For Alaska, Hawaii, P.O. Boxes, FPO, APO, please add \$4 to the above charges

Foreign orders: Global Priority Mail envelopes (to many countries) can accommodate up to 5 single molds (\$13.99 size) at a cost of \$15.00. E-mail us for additional overseas shipping costs. Any customs/VAT charges are the responsibility of the buyer.

New Jersey residents ONLY, please add 7% sales tax

CHECKS\*MONEY ORDERS\*VISA\*MASTERCARD\*DISCOVER

## Dutkins' Collectables

1019 West Route 70, Cherry Hill, N.J. 08002 PHONE: (856) 428-9559 FAX: (856) 428-9640  
e-mail us at [richd@dutkins.com](mailto:richd@dutkins.com) and visit us on the web at <http://www.dutkins.com>

# FRANKLIN MINT - THE AMERICAN FIGHTING MEN



Britains Figure shown right for size comparison

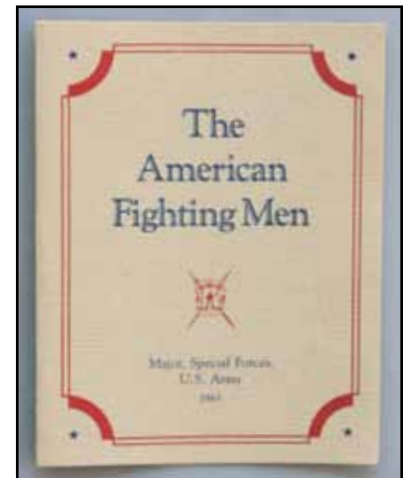

This 50-figure limited edition collection was issued by the Franklin Mint beginning in the mid 1980's. It was issued one figure each month until completed. Each figure is made of solid Pewter and is hand-painted. It was issued under the auspices of the American Military Historical Society and was sculpted by Ronald Hinote. It includes the original box containing an individual two-page description of each figure. Also included is the certificate of authenticity. The first figure is a minuteman from 1775 and the last figure is a Major, Special Forces, U. S. Army from 1965. Every major American uniform in the intervening years is represented. The figures are in mint condition. The

figures are in the 54mm range. All are labeled on the underside of the base. The display case is in excellent condition. It has two glass front doors with magnetic closures and measures 25" wide, 21.5 " high, and 4" deep. The collection is uncommon complete because it required over four years to acquire all of the figures.

Contact information:  
William Schneider  
8101 Osler Lane  
Knoxville, TN 37909  
(865) 690-5340  
plastybill@comcast.net





# BOOK REVIEW

## LES FIGURINES EN PLOMB CREUX TOME 3

*By Jean Bernard Doublet and Jean-Michel Tisne*

*Reviewed by Russ Bednarek*

Following the success of their first two volumes, authors M.Doublet and M.Tisne have released their long-awaited third book examining the work of French hollow-cast manufacturers. The newest release explores the products of C.B.G., D.C., S.R., and X.R. The authors continue to adhere to their successful format of informative text supported by a truly immense number of color photographs displaying the products of each manufacturer.

The companies examined in this study existed from the 1920's to late 1950's. It was during this period that diverse materials were introduced, experimented with, and utilized in toy soldier production. Aluminum, with its almost indestructible quality, was first used in the 1930's. Unfortunately the drawback to this medium was that detail was difficult to replicate in the castings, and paint adhesion was less than desirable. Later, plastic was introduced, a less expensive material that could be readily painted. To adapt to the ever shifting consumer trends of the toy soldier market, companies commonly used the same mold for their hollow-cast, aluminum and plastic figures to save time and expenses. This practice of multi-material production often makes figure identification confusing and difficult for the collector. When applicable, the authors clearly identify such figures utilizing a color coded numbering system, the color corresponding to the material used in the figure's production.

Identifying French hollow-cast figures can be a frustrating and extremely difficult task. Numerous companies ventured into the toy soldier market, many producing figures of diverse materials. To further complicate things, many companies stole from each other, be it creating figures to compete with a competitor's popular line, or literally re-casting a competitor's figure with a minor change. These practices further complicate attempts to document a company's production. The most reliable resources for research are original boxed sets bearing the

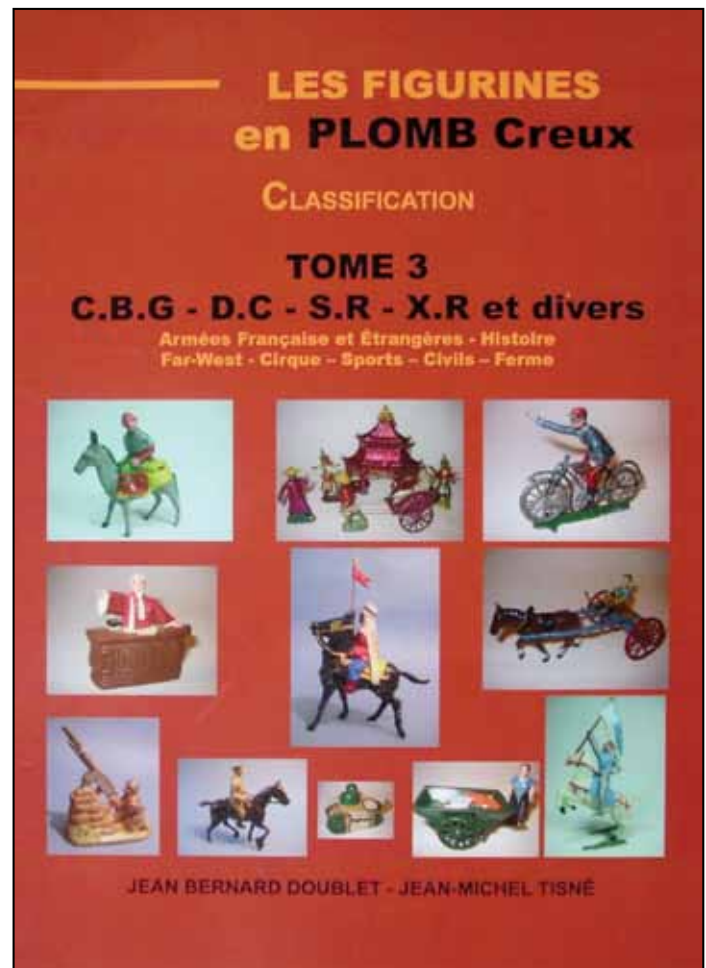

company's name/logo and catalogues. Collectors are treated to several pictures of boxed sets and multiple catalogue pages, the most numerous being color pages from the Tobler catalogue. Tobler was a manufacturer of chocolate that employed a promotional system of hollow-cast figures produced by D.C. Included with each Tobler chocolate bar was a stamp of a numeric value. The stamps could then be redeemed for D.C. figures, each figure requiring a specific number of "points" for redemption. Tobler had several different sized figures produced for their promotions, all of which are thoroughly examined. Color photographs of the catalogue and the corresponding figures are presented for study.

# BOOK REVIEW (Cont.)

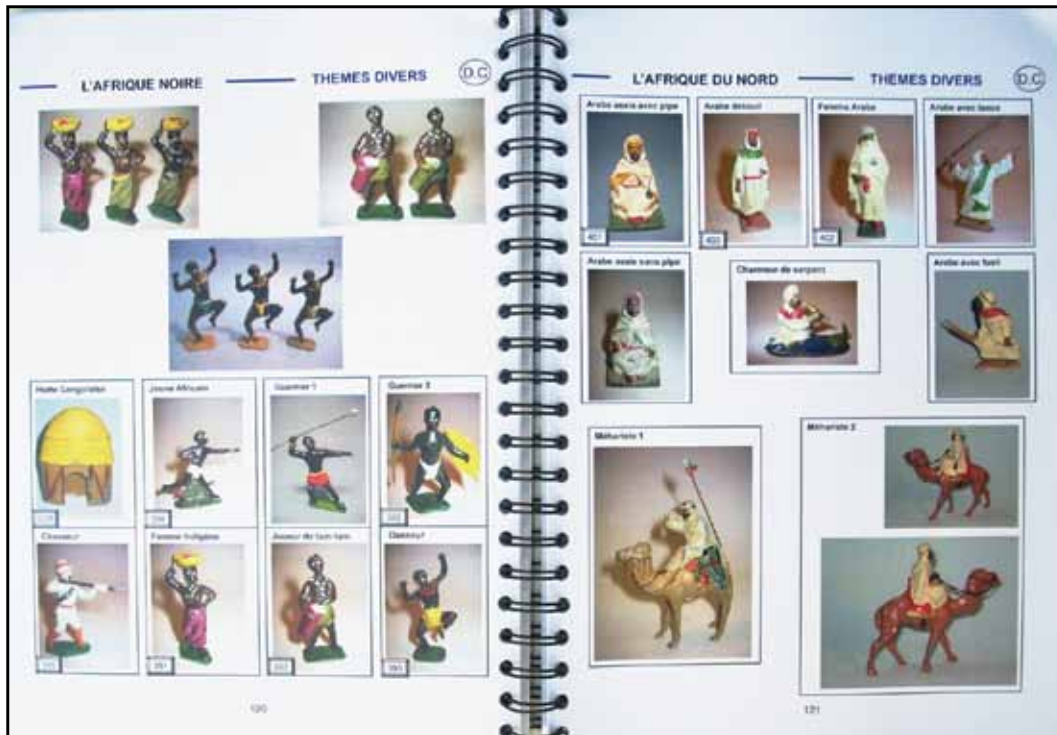

Collectors will find the chapter concerning S.R. (Simon et Rivollet) most interesting. S.R. was well known for their horse drawn artillery teams. In addition to the artillery teams, field kitchens and various military horse drawn wagons were created. To cater to the collector, the vehicles appeared in four different sizes, with some guns available in up to seven different scales. To compliment the common field artillery pieces, siege and fortress cannons were also produced. The sheer number, type and scale of S.R. products can be overwhelming to the collector, but with the numerous color photographs and supplementary text, one can successfully navigate the identification of an S.R. piece.

*“Les Figurines en Plomb Creux 3”* encompasses more than hollow-cast figures of the French Army. Foreign armies, Wild West, Circus, Sports, Civilian, Farm and Historical figures are also examined. There is a short chapter dealing with several smaller manufacturers and another presenting newly discovered figures that belong in the two previous books. Readers are also treated to nine pages of color photographs of figures, *“non identifiées”*, that are sure to be of great interest to collectors.

The quality of *“Les Figurines 3”* is consistent with the two previous books; outstanding. Printed on glossy, heavy paper, it is 238 pages, with almost one thousand color photographs, that will delight enthusiasts not only of French hollow-cast production, but hollow-cast collectors in general. Offered in a traditional binding, a spiral bound version is also available. My personal preference is the spiral bound version. Not only is it larger in size, but the spiral bound edition offers collectors the advantage to lay open any page of any volume to compare figures of different makers. Considering the amount of information plus the quality and quantity of color photographs, I highly recommend this book to all toy soldier collectors.

Collectors can confidently order their copy directly from Jean Bernard Doublet. M.Doublet accepts PayPal and his service and reliability is superb. I would like to thank M.Doublet who generously provided a copy for this review.

CONTACT INFORMATION  
jean.doublet@wanadoo.fr



# BOOK REVIEW

## The Barclay Catalog Book & The Second Catalog Book

*By Richard O'Brien*

*.... A review by Stan Alekna*

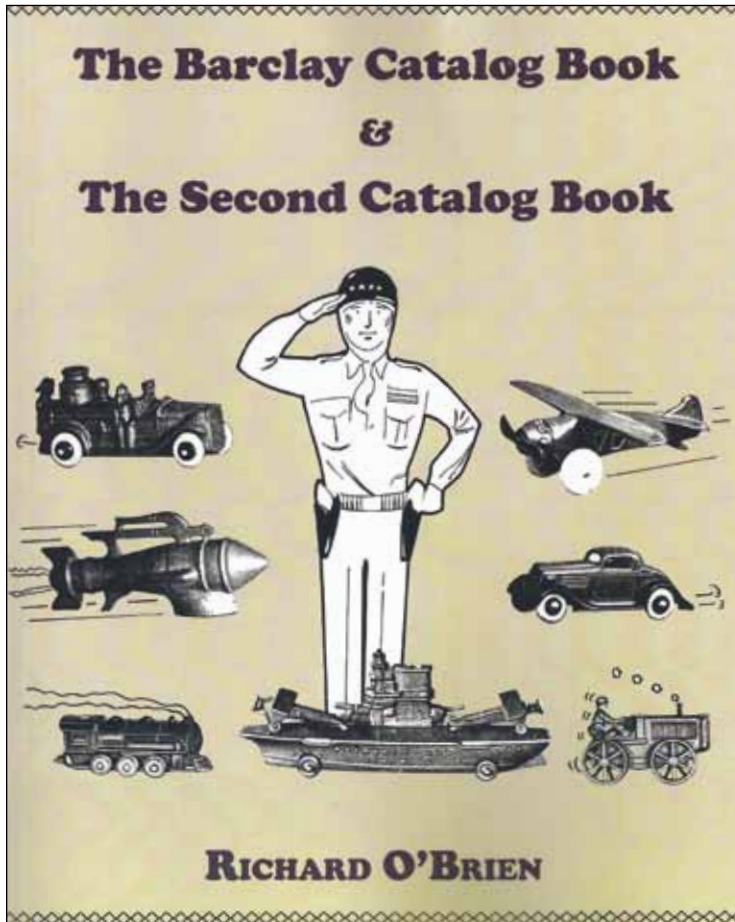

Richard O'Brien has combined his two, excellent, long out of print Dimstore reference books listed in the heading and had them republished into a single volume. It is an absolute must for any serious Dimstore collector. While both of the original books, published in 1985 and 1986 respectively were 13 inches by 8-1/2 inches, the new book is in 8 X 10 format.

The Barclay Catalog book section is 56 pages in length and contains catalog pages of most Barclay figures and vehicles along with photos of some prototype items that were never produced. Several very scarce items such as No. 365 Streamline (Zephyr) train and No. 151 Baby Crib with doll along with many boxed sets and several "Paint Your Own Army" sets are pictured and are not found in any other reference book including Collecting American Made Toy Soldiers.

The Second Catalog Book section is also 56 pages long and features original catalog pages from Manoil, Beton, Authenticast, Warren, All-Nu (Faben) Grey Iron and concludes with Barclay's post war items such as the super rare No. 390 Fire Engine with Climbing Fireman, their podfoot series and the small die cast vehicles of the 1960's that were Barclay's production "swan song".

I have used my copies of the two, original catalog books over the years to identify Dimstores that were not pictured or listed in any other volume or periodical. I hope that your review of this fine reference piece will also provide you with some answers to your own long-standing Dimstore puzzles and questions.

You can order the book on Amazon.com for \$20.00 or directly from the publisher, Ramble House; 10329 Sheaphhead Drive; Vancleave, MS 39565, or on-line at [ramblehouse.com](http://ramblehouse.com), for \$15.00. The original books cost \$15.00 each so this is a real bargain.



**THE AUSTRALIAN LOCATION**  
 For Metal and plastic toy soldiers and model figure kits.



Toy Soldiers makers including Frontline Figures, Conte Collectibles, King & Country, East of India, Britains, Tommy Atkins, Models from 5 St. Petersburg Studios, The Warrior Irish as well as 3 premier Australian makers. Model figure kits from Andrea, Pegaso and Metal Modeles.

**NEW ADDRESS**

WE SHIP WORLDWIDE  
**PETER NATHAN TOY SOLDIERS**  
 Shop 18, Level 2, Queen Victoria Building,  
 455 George St., Sydney, N.S.W. 2000 Australia  
 Tel. (612) 9267 5591  
 Website: [www.toysoldiers.com.au](http://www.toysoldiers.com.au)  
 E Mail: [peter@toysoldiers.com.au](mailto:peter@toysoldiers.com.au)  
 OPEN DAILY 10am - 6pm.



**Sierra Toy Soldier Company**

The finest Toy Soldiers from the heart of Northern California  
**King & Country, Britains, Conte, East of India, Grenada, Troiani to name just a few!**  
 New for 2005 - "Spartan Enomotarch - Battle of Thermopylae, 480 BC" - Grenada Studios."



Toy Soldier store located at  
 15466 Los Gatos Blvd, #108  
 Los Gatos, CA 95032  
 Toll Free (866) 869-7653 • International (408) 358-3910  
 Fax (408) 358 3966

**[www.sierratoyssoldier.com](http://www.sierratoyssoldier.com)**

**Armies of the World**  
**Britains Ltd. Lead Soldiers 1925-41**  
 by Joe Wallis

- contains 550 high-quality closeup photos of the military and civilian items produced during these sixteen years;
- totals 419 pages of comprehensive descriptions, including changes in the composition of sets, the years each item appeared in the catalog, and cross references to other sets;
- places photos in numerical order throughout the text, facing the set descriptions--in the same format as *Regiments of All Nations* by the same author.

Only \$40 postpaid in North America and for overseas surface mail delivery. Include an additional \$12 for airmail postage to England or Europe or an extra \$15 for airmail postage to Australia or New Zealand. Foreign orders must remit a check drawn on a U.S. bank or an International postal money order. Send your check or money order to:

Joe Wallis  
 P.O. Box 3407  
 Arlington, VA 22203-3407

**ALL NEW IN FULL COLOR!**  
***Regiments of All Nations***  
 by Joe Wallis

Now available is the hardcover, all color, revised edition of the definitive history of Britains Limited lead soldier production between 1946 and 1966. With 415 pages and 500 close-up color photographs even collectors who have the previous paperback edition will want to get this enhanced version.

The text describes the items produced in an easy-to-use format with color photos on the facing pages. The book details the roster of military sets, picture packs, and civilian lines (Farm, Hunt, Zoo, Circus, and Racing Colors), including color schemes, the dates of production, and changes in the composition of sets.

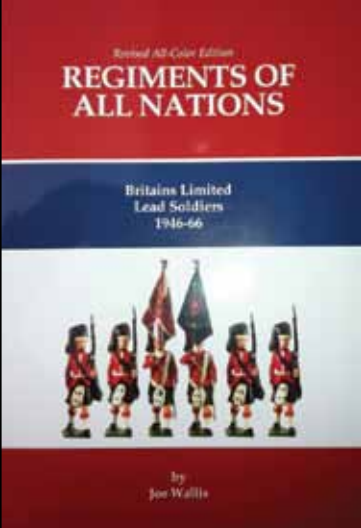

**\$60 USA/\$70 Canada/\$80 overseas; postpaid.**  
 Get your autographed copy directly from the author by sending a check or money order to:  
 Joe Wallis, P.O. Box 3407, Arlington, VA 22203-3407.



# Old Toy Soldiers and Figures 1900-1939

## Four Decades of Advertising

### Old Toy Soldiers & Figures 1900 - 1939

#### Four Decades of British Advertising

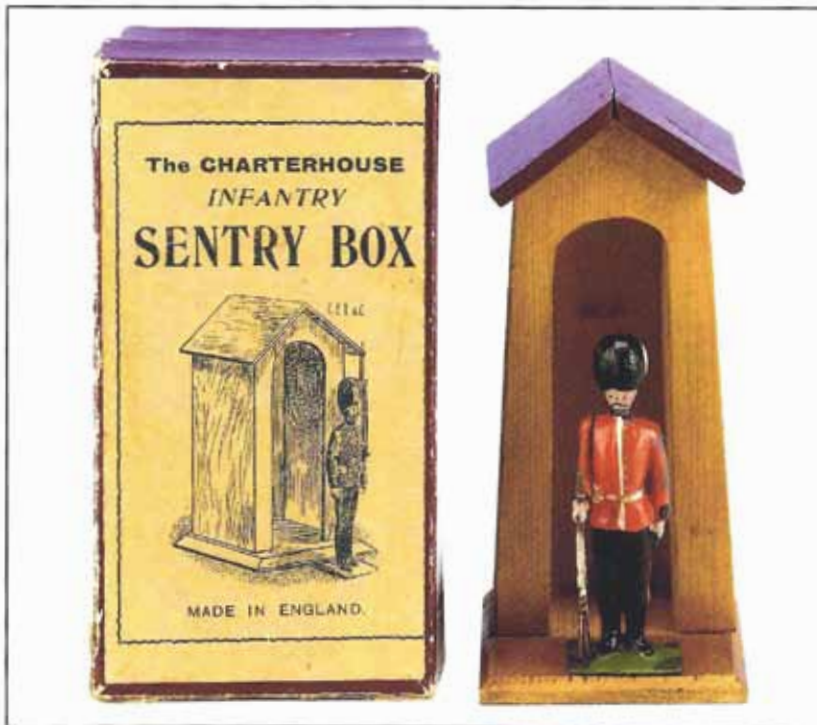

Norman Joplin & Philip Dean

#### Price including shipping & packaging within the USA is-

Soft Cover \$79.95 including Priority Mail or

\$77.82 including Flat rate Media Mail.

Hard Cover \$89.95 including Priority Mail or

\$87.82 including Flat rate Media Mail.

#### To order or for availability in UK, Europe or the rest of the world please contact-Norman Joplin.

Email [info@normanjoplin.com](mailto:info@normanjoplin.com) or telephone 262-692-3913

(Office hours Monday - Friday 8 am- 5 pm central time)

Or write enclosing check to

Norman Joplin, 535 Fir Street, Fredonia, Wisconsin 53021

Old Toy Soldiers and Figures 1900-1939 - Four Decades of Advertising is a unique record of Toy Soldier advertising from the World War 1 and pre World War 2 Periods.

Privately published and compiled by Norman Joplin and Philip Dean, it illustrates many advertisements never before available to Toy Soldier Collectors and is the result of over 40 years of research by Norman Joplin

The book also illustrates many individual rare single figures from the period and concentrates on over 30 manufacturers. Abel, Australian Hollowcasts, B.M.C, Chad Valley, Charterhouse, Cheerio Manufacturing Company, Crescent, EA Doran, Dunham White, CF Eckhardt, Exella, Faudel Phillips & Son, Fry, Erecto Toy Company, Godschalk, Hanks and Hanks Brothers and Sutton, A J Holladay, John Hill/Johillco, Kew, Laurie Hansen, Lord Roberts Workshop, Marlborough Manufacturing Company, Model Toys, Oliver Harper, Pixyland Manufacturing Company, Reka, Richards Art Company, Renvoize, Russell Manufacturing Company, Stoddarts, Wellington Toy Company, and G.W. Wood

While Britains are included to a certain extent the main focus is on the other makers of the period. Volume 2 which will be available in 2012 will concentrate solely on Britains advertisements of the same period and beyond.

Note: this book is only available directly from the authors, it will not be offered by Amazon or via any cut price on line merchant.

# AMERICAN DIMESTORE

## *Toy Soldiers & Figures*

Reviewed in OTS Fall 2000.

650 color photos in 240 page hardbound format.

\$59.95 plus \$3.50 book rate or \$6 by priority mail.

Signed copy on request.

Available from:

**Don Pielin**  
**106 Cottonwood Drive**  
**Streamwood, Illinois 60107**  
**Telephone 630-497-1239**  
**Email: dimestores@aol.com**

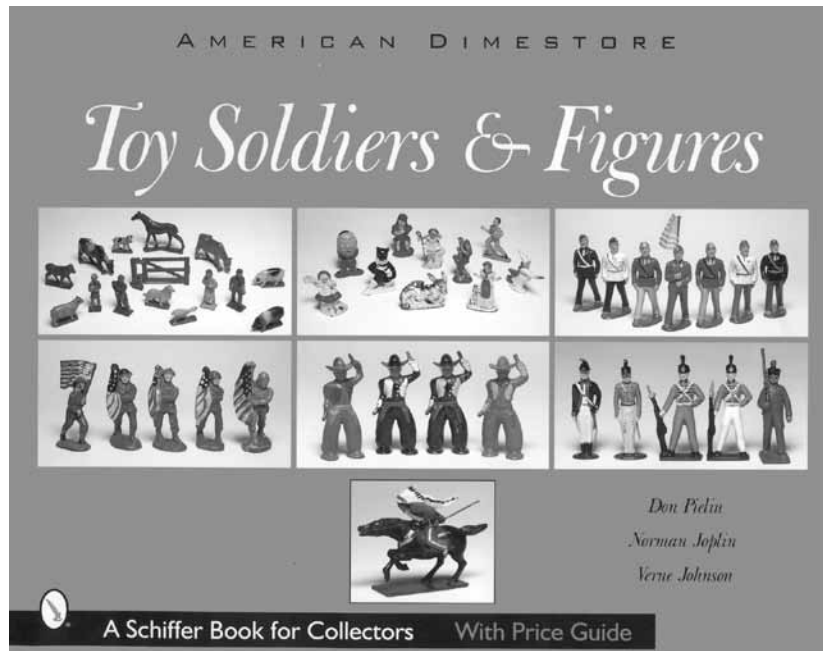

## CASTLE STONE MODELS®

**Manufacturer of Castles and Castle Components**  
 Acquire a complete castle or components:

- Curtain Walls
- Gate House
- Defense Tower
- Defense Walls
- Castle Keep



Perfect for occupation by 25mm figures or as a backdrop for larger figures. Complete castle is 17" x 17" x 9". Custom made with cast Hydrocal Plaster Cement. All patterns are original work. Great for scenery or military model backgrounds.

For further information and product description, please visit our website at [www.castlestone.com](http://www.castlestone.com) or email us at [castlestone@comcast.net](mailto:castlestone@comcast.net).

Castle Stone Models® – Wheaton, Illinois



## Antique Toy World Magazine

**The Old Toy Soldier of the toy world.**

**Published monthly for over 32 years.**

**One year U.S. subscriptions starting at \$39.95. A must for today's collector.**

**P.O. Box 24509, Chicago, IL 60634**



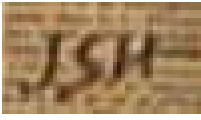

# J.S.H., THE MYSTERIOUS ILLUSTRATOR

By Joe Wallis



I have written this article to correct the often held misconception that all prewar illustrated box labels were drawn by Fred Whisstock. Whisstock, who lived from 1878 to 1943, designed over 140 box labels for Britains sets between about 1908 (or 1909) and 1930. Some of his labels continued in use until 1950. (For information on Fred Whisstock, including his obituary, see my 1997 article in *Old Toy Soldier*, Volume XXI, Issue Number 3, pages 23-25.) Collectors have long been captivated by Whisstock's artwork, although the vignettes that he drew sometimes demonstrated artistic license and inaccurately portrayed the pose adopted by the set's contents. (For example, Set #11 Black Watch Highlanders is charging, not marching as his label depicted it.) This may have caused occasional complaints from the firm's more fastidious customers. In addition, the style and lettering were probably seen by the Britains firm to be rather "behind the times" by the 1930s.

A generic "Armies of the World" box label was introduced for newly issued sets by 1933, but Whisstock boxes continued to be used for most of the previous sets that had them. In fact a few of his labels were reemployed for new sets: Set #1730 Royal Artillery Gunners and Set #1894 Royal Air Force adapted Whisstock's labels for Sets #313 and #240, respectively. However, there were at least eight—and possibly six additional—Britains sets that were given dramatic and impressive new labels during the period 1933-35 designed by an illustrator who only signed his work with the initials "J.S.H." in tiny letters (compared to Whisstock's full name he designed). J.S.H. was as good an artist as his predecessor, but only a few of his labels survived in use past 1941. If Whisstock sometimes drew scenes that featured poses not in the



Set # 1. The Life Guards



Set # 1257. Yeomen of The Guard



Set # 127. 4th/7th Dragoon Guards



Set # 128. 12th Royal Lancers



Set # 15. Argyll and Sutherland Highlanders



# J.S.H., THE MYSTERIOUS ILLUSTRATOR (Cont.)



Set #s 150 and 152 North American Indians



Set # 159. Territorial Yeomanry



Set # 24. 9th Queens Royal Lancers



Set # 30. Drums and Bugles of the Line



Set # 32. Royal Scots Greys

set, J.S.H. consistently produced attractive drawings that did not comport with the set contents.

The eight box labels which contain the initials of J.S.H. include: Set #1 Life Guards, Set #32 Royal Scots Greys, Set #128 12th Lancers, Set #150 North American Indians on foot, #152 North American Indians on horses, #159 Territorial Yeomanry, and #1258/#1307 Knights in Armor (which both used the same jousting scene). There are five more box labels that appear to be very much in the style of J.S.H., but lack his initials. These labels are: Set #15 Argyll and Sutherland Highlanders charging, Set #24 9th Lancers, Set #30 Drums and Bugles of the Line, Set #33 16th/5th Lancers, Set #127 4th/7th Dragoon Guards, and Set #1257 Yeomen of the Guard. I believe that the label for Set #1257 was the first one drawn by JSH, and that when he was asked by Britains to design more, the artist began to insert his initials in several subsequent box labels.

For the previously existing boxes with set numbers under 160, all but Set #15 had previously made use of Whisstock labels. The likely motivation for replacing the Whisstock labels for Sets #1, #33 and #127 was the need to reflect the changed regimental titles resulting from the 1922 reorganization of the British Army; this reduced 31 cavalry regiments to only 22 regiments by merging many units, including the 1st and 2nd Life Guards, the 16th Lancers and the 5th Lancers, as well as the 4th Dragoon Guards and the 7th Dragoon Guards. Britains did not follow through with redesigning the label for the 17th Lancers, which had merged with the 21st Lancers—probably because Set #81's 17th Lancers were dressed in the uniform they wore at the



## J.S.H., THE MYSTERIOUS ILLUSTRATOR (Cont.)



Set # 33. 16th/5th Lancers



Set # 1258/1307 Knights in Armour

battle of Ulundi in the Zulu War of 1879. Britains also never retitled Set #99 13th Hussars as the 13th/18th Hussars, nor Set #106 6th Dragoon Guards as the 3rd/6th Dragoon Guards.

Besides replacing the labels for merged regiments, Set #15 Argyll and Sutherland Highlanders had only had a "Printer's label" with battle honors, and it made sense to give it an illustrated box label. A desire for more dramatic scenes must have stimulated the replacement of Whisstock labels for Sets #24, #32, #33, #128, and #159. The North American Indian sets (#150 and #152) were given labels of a higher standard of artwork than Whisstock had devoted to them; probably to make them more likely to attract customers during the Great Slump when Britains was scrambling to maintain its sales.

Sets #15, #127, #128, and #159 were discontinued after 1941. For those sets which remained in the postwar catalogs, the new labels introduced in the 1930s that are discussed here survived until the early 1950s for Set #33 16th/5th Lancers, Set #150 Indians on foot, Set #152 Indians on horses, and Set #1307 Knights in Armor, while the J.S.H. labels

for Set #1 Life Guards, Set #30 Drums and Bugles of the Line, and Set #32 Royal Scots Greys lasted a few more years. Set #24 9th Lancers was sold in a box with the illustrated label for several years after the set's revival in 1954. The Yeomen in Set #1257 were offered in a box with a Historical Series label when it reappeared in the postwar Britains catalog in 1952—this label was shared with other sets such as the Waterloo Infantry of Set #1518 and the Knights of Agincourt on foot of Set #1664. (All photographs for this article are of boxes from my collection except for Sets #150 and #152, which Dr. Robert Cerwin loaned to me.)

Britains may have found new labels an extra expense whose impact on sales was hard to assess. In the end, generic Regiments of All Nations labels would prevail in the 1950s and cellophane-fronted boxes in the 1960s. Perhaps a reader of this article will be able to identify the full name of J.S.H. from other 1930s illustrations besides the toy soldier box labels that he did. If not, J.S.H. will remain the mysterious illustrator who succeeded Fred Whisstock and drew some excellently done Britains box labels.



MEMPHIS

# Toy Soldier LLC

Buying and Selling Metal Toy Soldiers

**OLD** and **NEW** metal toy soldiers representing many historical periods from the time of Napoleon through World War II, including the American Civil War.



Figures from such well known makers as Britains (old & new), Imperial, Edmunds, Hocker, and others.

- Write or email for periodic mail list.
- We buy old toy soldiers, Hocker and Imperial collections, including Dimestores.

### Permanent displays on sale at:

The Depot Antique Mall  
709 North Lamar  
Oxford, MS

Sheffield Antiques Mall  
684 West Poplar  
Collierville, TN

Yarbro's Antique Mall  
350 Carriage House Drive  
Jackson, TN

Norman Rodriguez 901-218-7046 memph toysoldier@bellsouth.net  
688 Eaton Street Memphis, TN 38120



Established 1991

## Purveyor of Antique & Modern Toy Soldiers, Miniature Figures, Antique Toys & Boats

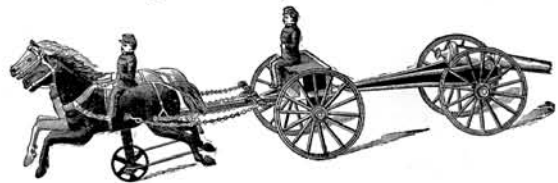

Visit our shop at:

628 Dixie Highway  
Rossford, Ohio 43460  
419 662 TOYS (8697)

I-75, exit 199,  
SR-65 south 1 mile.

Open by chance  
or appointment.

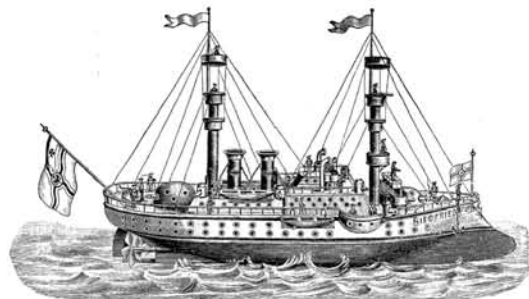

Purchasing toy soldiers,  
antique toys, boats, banks  
& related ephemera.  
Send listing or call. We travel.

[www.josephsaine.com](http://www.josephsaine.com)

## Northcoast Miniatures

Manufacturer of 54mm Metal Figures  
at 3/8 in. Scale (or 1-32)

Civil War  
figures, cannons, wagons



VICTORIAN BREWERY WAGON

Victorian Village & Western Americana  
figures, carousel, wagons

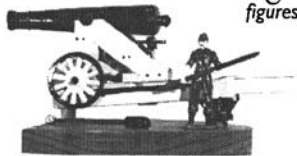

32-POUND SEACOAST GUN

Napoleonic Era  
figures



IRISH BRIGADE

Kazakh History  
figures

Circus  
wagons and clowns  
in 3/8 in. Scale



BARNUM & BAILEY CIRCUS CAGE

Judiann & Bob O'Connell • 7296 Oakmont Dr. • Santa Rosa, CA 95409  
(707) 537-7620

e-mail: [joconnell06@comcast.net](mailto:joconnell06@comcast.net) • website: [54mmtoyssoldier.com](http://54mmtoyssoldier.com)  
Catalog available for \$1.50



# ROGER ALLEN JOHNSON 1932-2009 DREAMT OF DIMESTORES THAT NEVER WERE... AND IMAGINATIVELY SAID WHY NOT!

By Louis S. Steinberg



**My Toy Soldier Hobby  
Was Always Gratifying**

*From its beginning the veracious axiom of sales and marketing has forever productively been, "Tell your story to enough prospects and someone will always say... Yes."*

*For the past few years, I have been writing about Dimestore soldier*

*producers, large and small, that rose to fill the void when the several majors ran out of road to kick the can down. After every article, it's been a consistent search for the next bonvivant name and a soldiering story yet to unfold. Sometimes that name has been unconscionably overlooked.*

*The cold salty skin moister quickly disappeared as soon as I began reading the review I received about a recent soldier show on a college campus in Hackensack, NJ.*

*My friend Roger Dubois wrote, "While at the Show discussing Dimestores with a few 'old timers' the name Roger Johnson came up. One in the group knew he was from*

*Metuchen, NJ, had made great toy soldier conversions, and sadly passed away not too long ago. I think I met him, however, it was very early in my hobby years and the name regrettably left me.*

*"I do remember from our recent correspondence your comment about running out of special Dimestore production people about whom to write.*

*"Anyway, upon returning home, I went online and searched for the obit of Roger Johnson, attempting to learn more. I was amazed to find out just how much this man had accomplished. He was definitely a generous man with many hobby talents.*

*"So you might wish to consider one more biography as another genesis or even an end to your anthology of OTS articles.*

*"Fortunately, I have been able to see some photographs of his workmanship and have a tremendous respect for his creativity in the fabrication of many fascinating Dimestore conversion pieces.*

*"I now regard Roger Johnson as one of the pioneers in the hobby of converting Dimestore toy soldier figures."*

Since the passing of Roger Johnson a few years ago, I am certainly lucky to acquire data from some of his industry friendships and from those that have collected his soldier creations as well as from his genteel wife, Marilyn.

Nowadays, the once Dimestore collecting universe by past standards has drastically shrunk to the likes of a specialized neighborhood. However, the conversion of Dimestore toy soldiers has taken on

the personality of a new art form. Thus, a different kind of current collectible demand has originated. It coat-tails nicely to the older originals.

Well, when first thinking about whom to contact for some input regarding Roger, I must begin with the person that influenced my own obsessive penchant to pursue the reconfiguring of aged, castoff Dimestore toy soldier figures.

A Grand Poobah in the toy soldiering hobby; a Master figure producer himself; a scholarly aficionado of Dimestore militaries'....none other than my longtime friendly potentate, Ed Poole.

Ed wrote, "Lou, I'm so glad you're doing an article about Roger Johnson. Roger responded in 1980 to an article I wrote in OTSN on WWII military vehicle kit models.

"This began a long enthusiastic correspondence. Throughout the years we did lots of swaps and traded many items, mostly soldier conversions. Roger had a lively imagination and, because he

## ROGER ALLEN JOHNSON 1932-2009 (Cont.)

possessed splendid modeling skills, he was able to put his ideas into creating great figures.

“Roger and I collaborated on two articles in 1994 and 2000 for *Toy Soldier Review*. Both returned us to our first mutual interest, tanks from old wood kits. He supplied the tanks for me to photograph. The crew and accessories were from my line of *5 and 10 Corps*.”

There is still a mention or so of Ed and Roger that I wish to relate when the later years of his illness became the topic.

I then approached Verne Johnson and asked him if he could forward me with a thought or so of Roger to include within this remembrance. He came forward with recall and kindness.

Verne stated, “Roger was the third person I became acquainted with in the toy soldier fraternity. He was the best mentor a new collector could have wished for, very sharing of his time and knowledge of all things to do with toy soldiers.

“Roger was always on the hunt for the unknown and the unrecorded Dimestore figure. His flea-

market travels and collectibles shows allowed him the opportunity to look under many tables asking each dealer about the odd toy soldiers they might have. More often than not he would come home with a new find.

“I think that as Dimestore toy soldiers began to become scarce because of the growing numbers of collectors, Roger’s interests also changed. He developed a strong desire for continuing the lines of Barclay and Manoil.”

I am told that this is the period when he began his serious fabrication of new toy soldier conversions never produced by the stale and musty regimes that before had ruled the market for so many years.

When asking Bill Lango about Roger, he had this to say, “Roger was very sophisticated and expressed a most likeable demeanor. At the shows, Roger’s table-top-displays were very presentable and always orderly in a most inspiring way for his potential buyers.

“He knew the ins and outs of salesmanship and connoted them from his years working in advertising and marketing agencies.



Photos Courtesy of Rodney Hopson



## ROGER ALLEN JOHNSON 1932-2009 (Cont.)

---



Photos Courtesy of Verne Johnson

"I remember one year, when Roger had the beginning of some illness, that I went down to his home, picked him up and off we drove to the big Miniature Figure Collectors of America Show at Valley Forge, PA. Roger, as always, found a bunch. The return trip was lots of laughs. He was in every respect surely an asset to our hobby."

In returning to Verne, another E-mail of his offered this aside, "When Roger began his earnest plunge into Dimestore conversions, he challenged himself to produce a Royal Canadian Mounted Police. He combined several cut-up figures into one. It was important that the R.C.M.P. maintained the look of an original piece, as if done by Barclay. His painting of all his military production was so exact as to march undetected along with the regular troops. He believed that if Barclay had made that Mountie, the kids of the era would have a buying frenzy."

"Roger enjoyed inviting you to guess what original figures went into one of his conversions. Many figures joined two to four parts of various originals."

"I am happy that Roger is being remembered and so recognized for the wonderful person that he was and for his part in introducing his Dimestore conversions to the toy soldier world and thus becoming part of that recorded history."

It is most pleasing to have accepted the memories of Roger from his hobby friends. Nevertheless, near the end of all the forgoing conversations I was asked this inquiry, "Have you talked to Charlie Breslow?"

No not yet. Marilyn emailed the phone number.

Although Charlie was recovering from several strokes, he was glib enough to speak at length about his long term friendship with Roger. Most of all, he took much quavering time to write me the following:

"It was the summer of '75, while I was shopping at the Chester, New Jersey flea-market, that I passed a table displaying my special interest, toy soldiers."

"The vendor, a man in his 30's, was friendly, interesting and was Roger Johnson."

"Having talked away the afternoon, then exchanging phone numbers, this began decades of a long friendship."

"When I first invited Roger to my home, he brought along a few new soldier creations for show-and-tell that he had made from casualties in his own collection. They became the beginnings of my

## ROGER ALLEN JOHNSON 1932-2009 (Cont.)

approximately hundred piece collection of R. J. conversions....perhaps, the largest grouping of his creations.

“Any collector will attest to the difficulty in shopping with someone who hunts for the same things you do. But, Roger and I always managed to amicably ‘divvy-up’ the treasures.

“Here’s an interesting Rogerism. He had an uncanny ability to describe what he wanted to find on any day we shopped. I recall him saying, ‘I want to get these Barclay Boy Scouts today!’

“Wow...Gee by Gosh by Golly!! He found all of them that day! With Roger’s skills, any repairs were no problem.

“Over the years, we traveled, attended and set-up together at too many various collectible shows to mention. Roger was constantly motivated by bits and pieces to create interesting Dimestore conversions that never were. He always felt they should have been produced by the ‘Big Guys.’

“Somehow I did not understand why he never signed his work. I often told him. But he never did.

“With Rogers passing, I lost one of my oldest and closest friends. The hobby lost an unsung ‘Giant!’

“Roger accomplished what so many strive for but few attain. He lives on through his work. He will always be remembered by me and within the hobby.

“Roger, I miss you and cherish you. Your devoted friend ....Charlie.”

While coordinating soldier information from friends of Roger, I was most elated to have spoken on several occasions to his wife, Marilyn, of almost fifty-five years. She graciously answered many questions and filled me in on some details.

Roger graduated Princeton University in the class of 1954. Unable to attend the 50th Reunion of his Class, since he had developed a progressive neurological condition, he dictated to Marilyn a brief bio for its submission into the Class Program, *Lives of '54*.

Quoted from that text: “ Upon graduating, three years were spent during the Korean War in the U. S. Navy as a Lieutenant supply officer on a sub



Photos Courtesy of Verne Johnson and Rodney Hopson.



## ROGER ALLEN JOHNSON 1932-2009 (Cont.)



Converted Barclay Podfoots to WW II Motorcycle Corpsmen  
Now Escorting Officer's Command Car



1941 U.S. Assault Boat Model with Fourteen Converted Manoil Soldier  
Figures Made by Roger in January 1998

tender and destroyer, and then followed by a career in advertising and marketing, marked by a variety of executive positions.

“Marilyn at that time taught sociology at Rutgers and researched women in politics at the Eagleton Institute. Two memorable years were spent in Germany where I worked for a subsidiary of Grey Advertising and where Marilyn did her dissertation research out of the University at Cologne.”

Interestingly, Roger also created and published five children's board games. Two of them *Sub Search* and *Tank Battle* became national-sales leaders.

Marilyn mentions and advised me, “no need to be shy about alluding to Roger's illness in your article as the last fifteen years of his life were affected, slightly at first then increasingly severely. His disability devastated the amount and quality of his conversions; as well as, his ability to read, write and navigate on his own.

“Marilyn continues, “During those fifteen years I was his caregiver. His room at home and our recreation room was decorated with Dimestore toy soldiers and vehicles. The walls were covered with WWII posters and prints. He repeatedly asserted and insisted that they all came from Ed Poole.

“Roger's final year was in a nursing home. I took him home every day to visit and play with his beloved poodle, Bertie, and his large miniature Army. At 76 the Lord took Roger.”

Roger, Marilyn and their two daughters, Marcia and Christina, were lifelong residents in Metuchen, NJ. In his youth he became an Eagle Scout. Those

were also the years when he began to collect toy soldiers from the local 5 and 10 cent store.

Roger's adult years found him serving on the Board of Education, the Racial Relations Council and as a Girl Scout troop leader and member of the Regional Girl Scout Council. As “Grandpa Roger” he entertained many children with stories and songs at the YMCA.

Roger is remembered by his friends in the hobby for his good humor and enthusiasm; his artistic conversion expertise; his willingness to share everything about toy soldering; and, his cheerfulness as a true toy soldier great.

I close with many plaudits to the help I received from soldier friends in crafting this article. Sincere thanks to Rodney, Roger D., Ed, Verne, Bill, and Charlie.

Marilyn, your effort, input and conversations were outstanding!

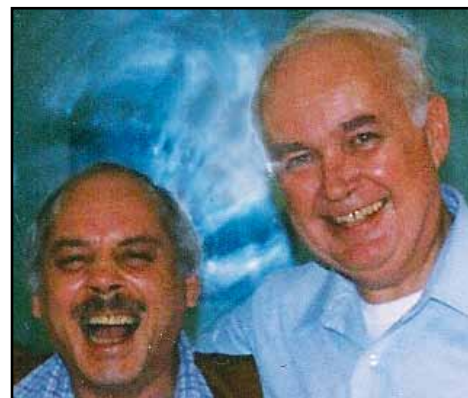

Three Decades with Best Friend Charlie  
Breslow “So What's to Laugh About?”

**STOCKADE MINIATURES, INC.**  
*A Toy Soldier Store*

*Featuring ...*  
*Our Continuously Growing Range of*  
*Soldiers of the World*

Napoleonic Wars • West Point Series • Crimean War  
Boer War • Zulu War • Guard Regiments  
Egypt & Sudan Wars • World War I • Indian Army  
American Civil War • Early American Wars  
French & Indian Wars • American Revolutionary War  
1066 • Mex & American War • Romans & Celts  
Boxer Rebellion • Franco-Prussian War  
North West Frontier • The Alamo Series

**VISIT OUR SHOP AT THE GATEWAY TO THE POCONOS!**

Michael & Norene Rosso  
4 North 6th Street, Stroudsburg, PA 18360

QUALITY OLD METAL  
& PLASTIC FIGURES  
BOUGHT • SOLD • TRADED

**570-424-8507**  
**FAX 570-424-8503**



**Belgian Composition**  
**Figures**  
**For Sale**

**All Manufacturers:**

Durso - Solido - NB - GJ, etc.

**All Series:**

Military - Western - Medieval -  
Circus, etc.

*Inquiries Welcome*

**Contact:**

Vin Russo  
P.O. Box 1031  
Woodbury, CT. 06798  
Tel: 203-266-4235  
Fax: 203-263-3716  
Email: vindotti@erols.com

*G. Scott Morlan*

*Toy Soldiers for Sale*

Free bimonthly listings of  
Britains, Johillco & more...

**boxed and unboxed**

Military and Civilian

sets and singles. Books too!

**New Collection Just In!!**

**Lots of postwar boxed sets**

Send for your listing today!

**G. Scott Morlan**

**P.O. Box 10701**

**Costa Mesa, CA 92627**

**949 574 9259**

**email is [scotoyz@hotmail.com](mailto:scotoyz@hotmail.com)**

*Christian B. Keller*  
**OLD TOY SOLDIERS FOR SALE**

Visit my two convenient locations in southern Pennsylvania for your Britains (boxed, unboxed, sets, singles, military and civilian), Dimstore, Elastolin, Lineol, Heyde, Mignot, and related accessories. You can expect excellent variety and condition in both stores. All items priced to sell.

• **ADAMS ANTIQUES** – Adamstown, PA. 2400 North Reading Rd. Take Rt. 272 North for one mile after exiting at the Reading interchange of the Turnpike. Two cases filled to the brim! Open daily 10-5, in the heart of PA's antique district. Note: This is not Adamstown Antique Gallery.

• **NORTHGATE ANTIQUES** – Carlisle, PA. 725 North Hanover St. 1 mile north of the square, between the entrance to the Carlisle Fairgrounds and the U.S. Army War College. Easy access from I-81. Open daily, 10-5.

**I BUY OLD TOY SOLDIER COLLECTIONS.**

**PLEASE WRITE OR E-MAIL:**

91 Harmony Hall Drive, Carlisle, PA 17015  
301-401-5339 • doktorkec@aol.com



WANTED

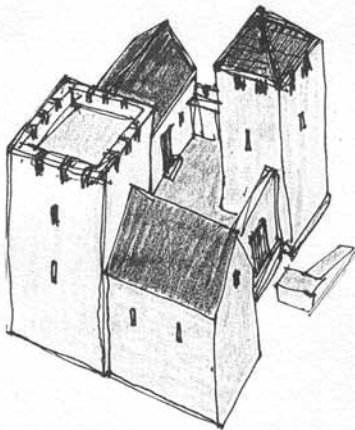

## OLD TOY CASTLES

CALL: PETER CLARK  
[202] 544-3348

WRITE: 516 A STREET, S.E.  
WASHINGTON, D.C. 20003

E-MAIL: psclark@verizon.net

## BUILD YOUR ARMY!

AMERICANS IN MINIATURE  
BRITAINS ★ CONTE ★ CORGI  
DUCAL ★ EDMUNDS  
FRONTLINE  
KING & COUNTRY ★ REGAL  
MARTIN RITCHIE  
SHENANDOAH ★ TRADITION

*Specializing in U. S. Marines of all time  
periods, American Civil War & other wars.  
Over 500 square feet of Toy Soldiers on display!*

**BUY • SELL • TRADE**

*Large selection of limited edition military  
art prints and books at discount prices!*

Stan Clark Military Books  
c/o Antique Center of Gettysburg  
30 Baltimore St.

Gettysburg, PA 17325 USA

Phone: 717-337-3669 • Fax: 717-337-0581

email: scmb@earthlink.net

## MOOREFIELD MINIATURES

*purveyors of the finest  
in vintage & collectible toy soldiers*

**proudly announce  
our latest acquisition**

**an important collection of Mint  
tied-in sets by Wm. Hocker**

**along with our usual wide selection  
of old toy soldiers by Britains, Mignot  
and other European manufacturers -  
sets & singles, boxed & unboxed**

*contact us for our current list*

## MOOREFIELD MINIATURES

4811 Merrimont Ave.  
Springfield, OH 45503  
phone (937) 399-6507  
email: www.roundbase@aol.com

*buying collections,  
large or small*

# BRUNTON'S BARRACKS

**Inventory varies from time to time  
and includes the following plus more:**

### CURRENT MAKERS:

Britains  
Mignot  
Alymer  
HM of Great Britain  
Hocker  
J G Miniatures  
King & Country  
Figarti  
Trophy

### EARLY TOY SOLDIERS:

Britains  
Johillco  
Composition  
Dimestore  
Blenheim  
Vertunni  
Garibaldi

Visit website to view many more products!

## BRUNTON'S BARRACKS

1019 COUNTRY CLUB DRIVE  
PRESCOTT, AZ 86303-3401

928-717-1698

Email: pam@bruntonsbarracks.com  
Webpage: www.bruntonsbarracks.com

*Unique - Quality -- Always*

## **Counterpane Gallery of Collector's Joys**

*- Established 1985 -*

One of the most trusted names among collectors

Britains, SAE,  
Barclay,  
Manoil, JoHill,  
Elastolin,  
Lineol, Heyde,  
Mignot, Grey  
Iron, Corgi,  
Dinky Toys,  
Solido...

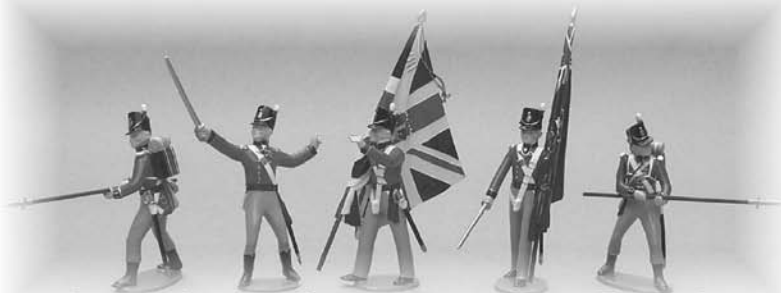

Imperial, Tiffany,  
Rose, Premier,  
Alymer, Banners  
Forward, Wall,  
Tradition,  
Ducal...

Appraisals, Consignments, Resale

(703)-536-3064

- Items offered are original in paint, casting, without repair & no longer produced -

Showroom: Daily 11- 5 pm

CountRpane@aol.com

250 West Broad St. (Rt .7)

Mail-Order: P.O. Box 6323

Falls Church, Virginia 22046



## **LA BOITE DE SOLDATS**



THE BEST CHOICE OF OLD TOY-SOLDIERS IN PARIS

Mignot, Lucotte, Gerbeau, Vertunni, Mim, Paris-Office,  
Heyde etc..

Elastolin, Linéol, French composition  
(S.F.B.J., Giroux, Résistex, J.R.D.)

French Hollow-Cast, Britains and  
others.

French plastics, paper soldiers,  
flats etc etc.....

NEW WEB SITE  
ADDRESS

**boitedesoldats.fr**

The web site address  
has changed  
**boitedesoldats.fr**

Phone/fax (0)1 45 78 89 44 [boitedesoldats@wanadoo.fr](mailto:boitedesoldats@wanadoo.fr)

Web-site **boitedesoldats.fr**

28 RUE VIOLET 75015 PARIS. FRANCE.

*A bientôt à Paris...*  
**François Beaumont**

Open Wednesday-Saturday 3-7



# PROTOTYPE OF MANOIL'S NO. 702 COUPE

*By Stan Alekna*

Our friends, Karl and Sheryl Thuman from upstate New York, who are avid Dimstore collectors, recently made a terrific addition to their collection. They acquired the original prototype, along with the U.S. Patent application and drawings, as submitted by Jack Manoil in 1935, for MANOIL's two-piece auto, NO. 702 – COUPE.

The prototype is slush cast, probably because MANOIL did not want to go to the expense of creating dies for die casting until the patent was approved. But die casting was the target process since the text of the application states in part "... directed toward toy automobiles which may be made out of cast material preferably by a die casting process." The patent application describes a two-part vehicle comprised of a chassis and body that was intended to be taken apart and reassembled easily, for play. Some early cast iron toy autos also had this feature.

As shown in the photo of the top view of the chassis and in figure 1 on sheet 1 of the patent drawing, the chassis contained a detailed 8-cylinder engine, drive train and gas tank (#20) that was visible when the body was removed. This certainly was intended to attract the attention of aspiring young auto mechanics and hopefully sell lots of toy cars.

The patent drawings show the smooth outline of the body of the slush cast prototype but the gray

extension lines around the perimeter of the body render much sharper corners as is seen on die cast production models of NO. 702. Another major difference between the prototype and the die cast production models is that the prototype has large, square air vents in the engine cowling whereas the production model has narrow, cast, vents as shown on the patent drawings.

We can only speculate as to the possible reasons for the major differences that occurred in the production model. The patent application goes into great detail to describe how the body could be attached and detached easily from the chassis. I believe that this attachment concept failed in practice and that the die cast "catches" that held the 2-parts together broke off rather easily. If true, then the obvious decision would have been to drop the attachment/detachment feature and to permanently assemble the body to the chassis, which is what they did. Having made this decision, it no longer made sense to go to the expense of casting the detailed engine, drive train and gas tank since they would not be visible in the permanently assembled car.

Lastly, an original catalog page of all four models of MANOIL'S NO. 70X, two-piece vehicles lists the various available colors for this series but the color of the prototype is not one of them. Too bad because I like the yellow color the best.



**NO. 702 – COUPE**



**BODY**



**CHASSIS TOP VIEW**



**CHASSIS BOTTOM VIEW**

# PROTOTYPE OF MANOIL'S NO. 702 COUPE (Cont.)

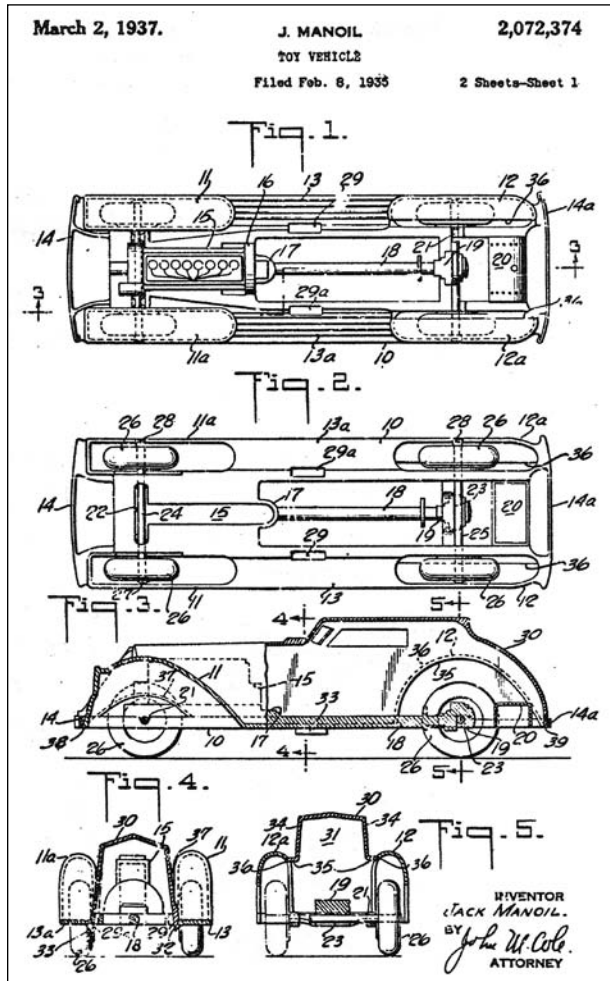

Patent Drawing 1

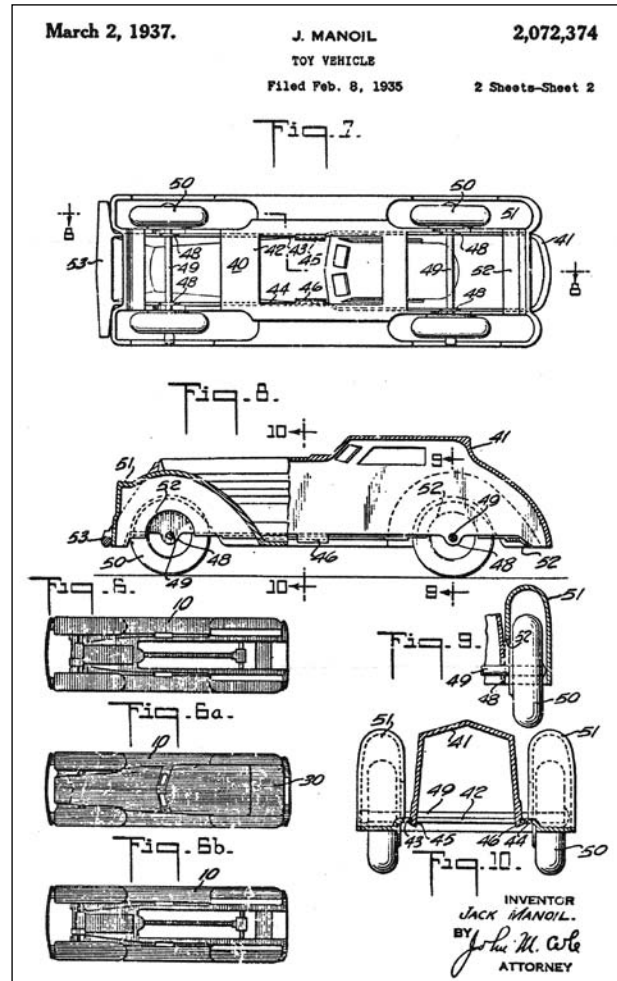

Patent Drawing 2

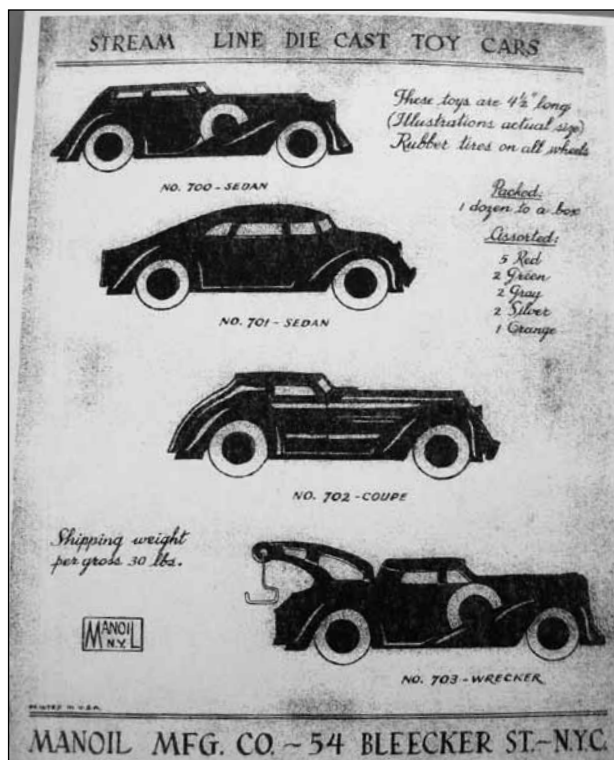

Catalog Sheet

Stan Alekna  
 732 Aspen Lane  
 Lebanon, PA 17042;  
 Phone (717) 228-2361  
 Email: salekna1936@yahoo.com



Patented Mar. 2, 1937

2,072,374

UNITED STATES PATENT OFFICE

2,072,374

TOY VEHICLE

Jack Manoil, Brooklyn, N. Y.

Application February 8, 1935, Serial No. 5,513

7 Claims. (Cl. 46-201)

The present invention relates to toy vehicles and is more particularly directed toward toy automobiles which may be made out of cast metal preferably by a die casting process. These toys consist principally of two castings, one a chassis forming casting and the other a body simulating casting. Axles and wheels complete the assembly of the toy vehicle.

The present invention contemplates toy vehicles of this class wherein the chassis part and body forming part may be detachably secured together and held against separation or relative movement by means entirely independent of the axles. The preferred form of detachable coupling means for securing these parts together includes catch members integral with the side walls of the body forming member and arranged to pass through the chassis forming member and hook against it so that the two parts will not separate. When the body forming part of the toy is in the form of die casting, the resiliency of the thin side walls (which may be constructed by die cast methods) makes it possible to permit pressing in these side walls sufficiently to accomplish the inter-engagement of the catch members and chassis.

By employing the quick detachable catch arrangement above referred to, it is possible to design the toy so that the wheels and axles may be completely carried by either the chassis part or by the body part, and the other part need not bear on the axles as has been customary in certain toys.

The present invention also contemplates a construction of toy automobiles wherein the wheels and axles are carried by the chassis portion so that the body portion may be completely disconnected from the chassis portion whereupon the chassis portion becomes exposed to view. This chassis portion may constitute a complete toy vehicle. It is preferably provided with elements which simulate the power plant and accessories usually found on the chassis of a regular automobile, i. e. the engine, clutch, propeller shaft, transmission, differential, and fuel tank may be simulated in the cast piece forming the chassis.

The present invention also contemplates the design of the chassis and body parts so that the body parts fit closely between the fender simulating elements of the chassis whereby the toy is reinforced mechanically and the lines of the chassis and body parts merge to provide an improved appearance in the completed toy.

A further object of the present invention is to provide a chassis part having a design which provides notches or bearings to receive the axle

shafts so that these axle shafts may be secured in place by merely passing the same lengthways through the notches and securing the wheels on the axles.

Inasmuch as the toy has the wheels and axles carried by the chassis, it may be provided with the accessories to more completely simulate the chassis of a full sized automobile. It is possible to readily decorate these enclosed chassis parts so that they will contrast with the decoration on the finished or completed toy automobile. The chassis may be sprayed one color, then the body placed on top of the chassis and another color of paint sprayed on so that the completed toy car is of uniform color throughout when the body is removed. The hidden parts of the chassis have the original color.

Other and further objects of the invention will be apparent as the description proceeds.

The accompanying drawings show, for purposes of illustrating the present invention, two of the many embodiments in which the invention may take form, it being understood that the drawings are illustrative of the invention rather than limiting the same.

In these drawings:

Figure 1 is a top plan view of a chassis forming casting;

Figure 2 is an inverted plan view of the chassis casting of Figure 1;

Figure 3 is a longitudinal sectional view taken on the line 3-3 of Figure 1, parts of the body being shown;

Figure 4 is a transverse sectional view taken on the line 4-4 of Figure 3;

Figure 5 is a transverse sectional view taken on the line 5-5 of Figure 3;

Figures 6, 6a, and 6b are diagrammatic top plan views showing the steps of decorating the chassis and body part;

Figure 7 is an inverted plan view of a modified toy automobile;

Figure 8 is a section taken on the line 8-8 of Figure 7; and

Figures 9 and 10 are sections taken on the line 9-9 and 10-10 of Figure 8.

The chassis casting 10 shown in Figures 1 and 2 is designed to simulate a regular automobile with the body removed to display the chassis and power plant. It has front fender simulating portions 11 and 11a, and rear fender simulating portions 12 and 12a. The fender simulating portions are integral parts of the chassis forming casting and are connected together by running board simulating portions 13 and 13a. These



# **HENRY KURTZ, LTD.**

*Auctions and Appraisals of Toys and Miniature Soldiers*

163 Amsterdam Avenue • Suite 136 New York, New York 10023

Tel: (212) 642-5904, or Fax (212) 874-6018

## **CONSIGNMENTS WANTED FOR FUTURE AUCTIONS**

- We also purchase collections and individual items.
- Let us appraise your collection and assist you in determining the best way to dispose of it.
- Reliable and dependable; 23 years in the field of selling toy soldiers (including 11 years as lead soldier specialist for Phillips Auctioneers)

*For further information, to consign items or to be placed on our mailing list, contact:*

**HENRY KURTZ at (212) 642-5904, or Fax (212) 874-6018**

*or write to*

Henry Kurtz, Ltd., 163 Amsterdam Avenue, #136, New York, NY 10023

## **ARLEY L. PETT ANTIQUES**

Toy Soldiers and Civilians  
Lead, Garden, Circus, Hunt,  
Farm, RR and Zoo Figures  
Military Vehicles and  
Related items

Arley L. Pett  
12 Beach Road  
Gloucester, Ma 01930  
(978) 283-2612, Fax (978) 283-2496  
E-Mail APett92117@AOL.COM



# The Old Toy Soldier Home

20 Years of Service, A Lifetime of Playing!

The West Coast's Oldest Dealer in King & Country, Britains, Trophy of Wales, Imperial of New Zealand, John Gittins' Diorama OLD and NEW!



977 S. Santa Fe Avenue • Vista, California 92083-6911 USA  
 Phone (760) 758-5481/FAX (760) 758-7004  
 Open Monday-Friday 10-5; Saturdays 10-2  
 Visit our site: <http://www.oldsoldierhome.com>  
 Email: [oldsoldierhome@earthlink.net](mailto:oldsoldierhome@earthlink.net)



## Now Available!

### Britains New Toy Soldiers

1973-PRESENT

TRADITIONAL GLOSS-PAINTED METAL MODELS



NORMAN JOPLIN & JOHN T. WATERWORTH  
 PHOTOGRAPHY BY PHILIP DEAN, ABIPP, ARPS

WITH PRICE GUIDE

Order your specially signed copy of  
*Britains New Toy Soldiers 1973 to the Present*  
 by contacting Norman Joplin

535 Fir Street • Fredonia, Wisconsin 53021  
 Telephone: 262-692-3913 • 262-388-1140  
 Email: [info@normanjoplin.com](mailto:info@normanjoplin.com)  
[www.normanjoplin.com](http://www.normanjoplin.com)

Price is: \$99.99

US Mailing  
\$5.00

Canadian Mailing  
\$22.60

UK Mailing  
\$37.50

## The Great Book Of Britains, Limited Edition by James Opie

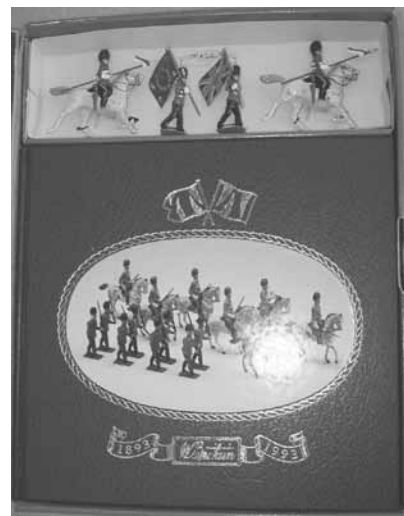

Offering a very limited number of this out of print book. Over 600 full color pages make this the ultimate reference book. Includes limited edition set of soldiers. Price \$450 Standard edition \$325

## RAY HARADIN TOYS OF YESTERYEAR

1039 Lakemont Dr. • Pittsburgh, PA 15243

1-800-349-8009 or 412-343-8733 • fax 412-344-5273



Shipping and handling \$25,  
 overseas shipping \$50.



# TOY SOLDIER MARKETPLACE

## WANTED



### WANTED EARLY AND PREWAR BRITAINS TOY SOLDIERS

Sets. Collections.  
Excellent condition or better.  
Prefer boxed. Norman Rodriguez at  
901-218-7046 or nkrod@bellsouth.net

### WANTED

Small Dimstore collections  
Norman Rodriguez  
MEMPHTOYSOLDIER@bellsouth.net  
901-218-7046

### WANTED

New to Like New, Great Book of Britains,  
by James Opie paying \$200 per copy  
1-412-343-8733

### WANTED

Britains Paris Office - Toy Soldiers and Catalogs.  
Contact: Rob Wilson.  
E-mail: r.a.wilson@warwick.ac.uk.  
Telephone: 011-44-1926-496062.

### BUYING ENTIRE COLLECTIONS OR SINGLE PIECE

Acquiring exceptionally fine quality figures at the highest prices: Especially interested in Britains, Dime Store, Heyde, Lineol, Elastolin, Marklin, Courtenay, Vertunni, American Soldier Company, Auburn Rubber, French Aluminum, Warren and Early Plastic figures.

Photographs will be required.

Ray Haradin, 1039 Lakemont Dr., Pittsburgh, PA 15243.

E-mail: Raytoys@aol.com. Fax: (412) 344-5273.

CALL: 1-800-349-8009

Heyde Nippes and Civilian Sets, also semi solid  
Spenkuch and Munklefigures wanted.

Please send photos to gisbert.freber@gmx.de

Holger Eriksson Collectors Society Newsletter HE

Seeks information about the make-up

of these S.A.E. 30mm green-boxed sets of 6 pcs:

- #6TV U.S. Army Television Combat Unit
- #31M Yugoslav Infantry marching 1957
- #32A Albanian Infantry action 1957
- #32B Bulgarian Infantry action 1957
- #121 Nigerian Infantry action 1957
- #123 Mauritius Infantry action 1957

If you have one of these rare sets or a figure from a set,  
Please contact Lou Sandbote at new address/phone:

Louis J. Sandbote

6060 N. Central Expressway, Suite 560

Dallas, TX 75205

or lou.sandbote@charter.net

or call 214-522-4012

### WANTED WM HOCKER TOY SOLDIERS

Sets. Collections. Excellent condition or better.

Prefer MIB. Norman Rodriguez at

901-218-7046 or nkrod@bellsouth.net

### Toy Soldier Marketplace Advertisements Rates.

20 Words \$5, plus \$5 for each additional 20 words.

Submit ads to:

**Old Toy Soldier**

P.O. Box 13324

Pittsburgh, PA 15243-0324.

Fax (412) 344-5273

E Mail: raytoys@aol.com



# TOY SOLDIER MARKETPLACE

## FOR SALE



### BEST SELLING BOOKS

*Regiments of All Nations, Britains Limited Lead Soldiers 1946-66* (new 415 page revised hardcover edition with 500 color photos); and *Armies of the World, Britains Limited Lead Soldiers 1925-41*. See website: [www.leadsoldierbooks.com](http://www.leadsoldierbooks.com) for order forms and costs.

Mail with payment to  
Joe Wallis  
P.O. Box 3407  
Arlington, VA 22203-3407

### BELGIAN COMPOSITION FIGURES FOR SALE

All Manufacturers, Durso - Solido - NB - GJ, etc. All Series and Military - Western, Medieval - Circus, etc. Inquiries welcome. Contact:

Vin Russo  
P.O. Box 1031  
Woodbury, CT 06798  
Telephone 203-266-4235  
Fax 203-263-3716  
Email [vindotti@erols.com](mailto:vindotti@erols.com)

### DIMESTORES FOR SALE

Over 500 figures, most 95%+ Barclay, Manoil, Grey Iron, and others. Also buying Dimestores.

Send name and address for next catalog to:  
Stan & Sally Alekna  
732 Aspen Lane  
Lebanon, PA 17042-9073  
Phone: (717) 228-2361  
E-mail: [salekna1936@yahoo.com](mailto:salekna1936@yahoo.com)

### LAFITTE MINIATURES OF NEW ORLEANS

WW2, Civil War, Jazz, Mardi Gras and many others including unique pieces.

Commissions welcome.  
[www.lafiteminiatures.com](http://www.lafiteminiatures.com)  
or contact [mikeswohl@aol.com](mailto:mikeswohl@aol.com)  
504-896-9008

### FOR SALE

Civilian Toy Figures - many rare and unusual items. For free lists email [info@normanjoplin.com](mailto:info@normanjoplin.com) or see full page ad in this issue.

### JOHN TUNSTILL'S 54mm FIGURES

Lambeth, London, 1970's were also produced in small, specialised quantities for an Italian Count. These are now for sale. Only six boxes of eight figures were ever made. Unique, rare, collectible, investments.  
[www.soldierssoldiers.com](http://www.soldierssoldiers.com)

### FOR SALE

#### WM HOCKER TOY SOLDIERS

Sets. MIB from large collection. Some 1st editions. Discount for multiple purchases. Call or email for list.  
Norman Rodriguez at  
901-218-7046 or  
[nkrod@bellsouth.net](mailto:nkrod@bellsouth.net)

### TRADITION SOLDIERS FOR SALE

English and French soldiers (boxed mint cond.) Multiple sets of infantry, cavalry, and artillery with crews. All sets are Waterloo period. Call or email for free list and prices  
Bob Luyckx  
ph: (248) 338-9665  
Email: [luyckx1@comcast.net](mailto:luyckx1@comcast.net)

### FOR SALE 1990s BRITAINS SETS

From large collection. Mint condition with boxes. Includes hard to find sets such as airplanes, tank, AA truck, Naval armored car, elephant, Lawrence of Arabia, etc, etc. Call or email for list. Norman Rodriguez 901-218-7046  
[memph toysoldier@bellsouth.net](mailto:memph toysoldier@bellsouth.net)

### FOR SALE

Hundreds of Imperial (MIB), plus old Alymer; Blenheim; Britains (old and new); Ducal; Marlborough; Tradition; Ron Wall; Elastolin and more!

Send \$3.00 (refundable) for 42-page catalog:  
Jack Paquette  
2355 Parliament Square  
Toledo, OH 43617  
419-841-8131  
Email: [jpaquette1@frontier.com](mailto:jpaquette1@frontier.com)

The best in Britains, Dimestore and German Lead. Call for free catalog.  
412-343-8733

### OLD TOY SOLDIERS FOR SALE

A well known and long established Toy Soldier expert, offers regular lists of Britain's Hollow Cast and Other Makers, and occasionally Continental, Composition and Plastic.

My lists since 1970 have formed the basis of many fine collections. These are issued about 4 times a year and can be emailed to you if required. Money back guarantee on all items, fast efficient shipping. Please state your interests and enclose your address and email (if available)  
G.M. Haley  
Hippins Farm, Blackshawhead, Hebden Bridge, West Yorkshire England, HX7 7 JG  
Telephone (for the US)  
011 44 422 842484.  
Email: [gedhaley@yahoo.co.uk](mailto:gedhaley@yahoo.co.uk)

### FOR SALE

All sets from IMPERIAL Productions, NZ end-of-the-product line. Counterpane Gallery.  
703-536-3064 or  
[CountRpane@aol.com](mailto:CountRpane@aol.com)

# TOY SOLDIER SHOW & AUCTION CALENDAR 2012

## 2012

**May 12 Saturday.** Virginia War Museum Toy Soldier Show. Contact Colin Romanick 757-247-8523.

**May 18-19 Friday & Saturday.** Miniature Figure Collectors of America. MFCA Valley Forge Convention Center King of Prussia. PA. See MFCA Web site for details.

**May 19 Saturday. 10 am - 4 pm.** Toy Soldier Museum, Cellar Sale Open House. Jim Hillestad 570-629-7227

**May 20 Sunday.** Ohio Toy Soldier Show. Contact dmclure@zoominternet.net

**May 26-27 Saturday and Sunday.** Texas Toy Soldier Show Menger Hotel San Antonio. Contact Martin@kingsx.com 210-226-7000.

**June 2nd and 3rd -Saturday & Sunday.** Old Toy Soldier Auctions USA. Contact Ray Haradin 1-800-349-8009 raytoys@aol.com or Norman Joplin 262-692-3913 info@normanjoplin.com www.oldsoldierauctions.com

**June 7 - Thursday.** Bonhams. Stewart Saxe Collection. Contact Leigh Gotch +44 208 963 2839 Email leigh.gotch@bonhams.com

**June 30 - Saturday.** Toy Soldier Show London. Royal National Hotel. Contact Guideline Publications Email regisaucklamd@btinternet.com 44-908-274433

**July 10 - Tuesday.** Vectis Toy Soldier Auction. Contact admin@vectis.co.uk +44 1642 750616

**July 21 - 22 Saturday and Sunday.** Toy Soldier Extravaganza. Livonia, MI. Contact 419-662-8697

**July 25 - Wednesday.** Bonhams Toy Soldier Auction, Montpelier Street. Knightsbridge London UK. Contact Leigh Gotch 44(0)-208-963-2836 www.bonhams.com

**September 8 - Saturday. Norman Joplin's Old Toy Soldier and Figure Show, Holiday Inn Bloomsbury London**  
Contact info@normanjoplin.com 262-692-3913. See ad in this issue.

**September 22nd - Saturday. Old Toy Soldier Auctions Annual Bargain Room Sale Hyatt Regency Schaumburg during the Chicago Show. Contact Ray Haradin raytoys@aol.com 1-800-349-8009 or Norman Joplin info@normanjoplin.com 262-692-3913.**

**September 23 - Sunday. Old Toy Soldiers Show Chicago. Schaumburg Hyatt Regency**  
Contact Don Pielin dimestores@aol.com See ad in this issue

**November 4 - Sunday.** 30th Annual East Coast Show. Hackensack, NJ. Contact 973-831-8900

**November 4 - Sunday.** Cantigny Classic Toy Soldier Show. Cantigny Park, WI. Contact Nick Albanese 920-261-1323 Email camprandall@charter.net

**December 1 - Saturday.** Toy Soldier Show London. Royal national Hotel. Contact Guideline Publications Email regisaucklamd@btinternet.com 44-908-274433.

## 2013

**March 10 - Sunday.** 24th Annual West Coaster. Irvine Marriott, CA. Contact 760-758-5481

*Dates and times are correct at the time of printing; however, it is strongly advised that before traveling, contact is made with show organizers to confirm date(s).*

## Advertisers Index

---



Alekena, Stan Email: salekna1936@yahoo.com Tel: 717-228-2361.....	27
American Dimestore Toy Soldiers and Figures - Book (Pielin, Joplin & Johnson) Email: pielin@aol.com Tel: 630-497-1239...	48
Antique Toy World Magazine PO Box 24509, Chicago, IL 60634.....	48
Arley L. Pett Antiques Email: APett92117@aol.com Tel: 978-283-2612 Fax: 978-283-2496 .....	64
Armies of the World - Book, Joe Wallis .....	46
Belgian Composition - Vin Russo Tel: 203-266-4235 Email: vindotti@erols.com.....	58
Bonham's Auctions Contact leigh.gotch@bonhams.com .....	22
Britains Civilian Toy Figures Tel: 262-692-3913 Email: info@normanjoplin.com .....	27
Brunton's Barracks www.bruntonsbaracks.com Email: pam@bruntonsbaracks.com Tel: 928-717-1698 .....	59
Castle Stone Models www.castlestonemodels.com Email: castlestonemodels@comcast.net .....	48
Clark, Peter Tel: 202-544-3348 Email: psclark@verizon.net.....	59
Counterpane Gallery Email: countRpane@aol.com Tel/Fax: 703-536-3064 .....	60
Dutkins Collectables www.dutkins.com Email: richd@dutkins.com Fax: 800-682-8163.....	41
East Coast Toy Soldier Show Hackensack Tel: 973-831-8900 Bill Lango .....	31
Green's Collectables www.greenscollectables.com Email: ma52557@aol.com Tel: 973-627-4961.....	35
Henry Kurtz, Ltd. Tel: 212-642-5904 Fax: 212-874-6018 .....	64
Hobby Bunker www.hobbybunker.com Email: matt@hobbybunker.com Tel: 781-321-8855 Fax: 781-321-8866.....	33
Hocker, William Tel: 510-841-4458.....	4
Keller, Christian B. Email: doktorkec@aol.com .....	58
King and Country Tel: Hong Kong (852) 2861 3450 Email: sales@kingandcountry.com .....	IBC
La Boite De Soldats Tel/Fax (0) 1 45 78 89 44 .....	60
Le Petit Soldat www.lepetitsoldat.com Email: jcarleton@aol.com Tel: (314) 567-3311 .....	35
Memphis Toy Soldier Tel: 901-218-7046 memphistoysoldier@bellsouth.net.....	52
Moorefield Miniatures 937-399-6507 .....	59
Morlan, Scott G. Tel: *82 949 574 9259 email: scotoyz@hotmail.com.....	58
Norman Joplin's New Book <i>Old Toy Soldiers and Figures 1900-1939</i> Email: info@normanjoplin.com.....	47



## Advertisers Index (Cont.)

---

Norman Joplin's Old Toy Soldier Show Email: info@normanjoplin.com .....	29
Northcoast Miniatures 54mmtoyssoldier.com Email: joconnell06@comcast.net Tel: 707-537-7620 .....	52
Ohio Toy Soldier Show Contact Tel: 330-722-6751 .....	27
Old Toy Soldier Back Issues Email: raytoys@aol.com .....	3
Old Toy Soldier Home www.oldtoysoldierhome.com Tel: 760-758-5481 Fax: 760-758-7004.....	65
OTSN Chicago Show Contact 630-497-1239 Email: dimestores@aol.com .....	30
Peter Nathan Toy Soldiers Tel: (612) 9279 2668 Fax: (612) 9279 2658 www.toysoldiers.com.au Email: peter@toysoldiers.com.au .....	46
<i>Regiments of All Nations</i> Book - Joe Wallis .....	46
Rodden Heraldic Sculpture roddenheraldic.com Tel/Fax: 603-742-7480.....	34
Rodneys Dimestore Gallery Tel: 850-932-6522 Email: castings1@att.net .....	13
S.A.S. Auctions Contact Email: toys@specialauctionservices.com 00 44 1635 580595.....	21
Saine, Joseph / Toy Soldier Extravaganza 419-662-8697 www.josephsaine.com .....	28 & 52
Sierra Toy Soldier Company Tel: 408-564-4133 Fax: 408-257-0166 www.sierratoyssoldier.com.....	46
Stan Clark Military Books Tel: 717-337-3669 Fax: 717-337-0581 Email: scmb@earthlink.net.....	59
Stockade Miniatures - Michael and Noreen Russo Tel: 570-424-8503.....	58
Toy Soldier Shop 202-546-2201 toysoldiershop.com.....	27
Toymaker of Williamsburg, The www.toymakerofwilliamsburg.com Tel 800-343-8697 .....	5
Toys of Yesteryear Ray Haradin Email: raytoys@aol.com Tel: 1-800-349-8009.....	IFC-65
Tradition of London Limited www.traditionoflondon.com Email: shop@traditionoflondon.com Tel: 011-44-207493-7452 Fax: 011-44-207355-1224 .....	BC
Treefrog Treasures Tel: 866-394-2418 or 507-545-2500 Fax: 507-545-2502 sales@treefrogtreasures.com www.treefrogtreasures.com .....	6
Vectis Auctions www.vectis.co.uk Email: admin@vectis.co.uk Tel: 011-44-1642-750616 Fax: 011-44-1642-769478 .....	22
West Coaster Toy Soldier Show Tel: 760-758-5481 .....	32

KING & COUNTRY'S

BR083



# 23 Fighting Fusileers

The Coat of Arms of the British Crown featuring a lion and a unicorn supporting the Royal Symbols of England, Scotland, Ireland and Wales.



**I**T'S BEEN FAR too long since we provided some reinforcements for our brave and noble 23<sup>rd</sup> Royal Welch Fusileers fighting the upstart rebels in the American Colonies.

Well all that is about to change with the imminent arrival of no less than seven additional "Fighting Fusileers" to add to collectors' regiments.

Among these new reinforcements are a Young Officer BR085 carrying a "Brown Bess" musket together with three different Marching Fusileers - BR086, 87 and 88. Another Fusileer, BR089 advances to battle with musket and bayonet to the fore.

Providing the martial music for our Regiment of Fusileers are a pair of battalion Musicians... The Fifer BR084 and Drummer BR083.

## ABOUT THE 23<sup>rd</sup>.

This famous REGT. fought at LEXINGTON and BUNKER HILL. They even served as *marines* aboard Admiral Lord Howe's fleet for a time...

Following *sea-service* they saw much hard-action at BRANDYWINE and CAMDEN.

Discerning Collectors seeking to purchase these fine toy soldiers need look no further than the noted, well-respected and eminently trustworthy KING & COUNTRY.

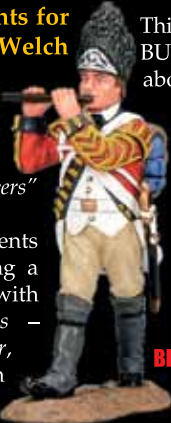

BR084



BR085

BR086

BR088

BR087

## KING & COUNTRY

AUTHENTIC HAND-MADE HISTORY

Available around the world wherever fine quality military miniatures are sold.

### KING & COUNTRY HEADQUARTERS

Suite 2301, 23rd Floor, No.3 Lockhart Road,  
Wanchai, Hong Kong  
Tel : (852) 2861 3450 Fax : (852) 2861 3806  
E-mail: sales@kingandcountry.com

### KING & COUNTRY SHOP

245, Pacific Place, 88 Queensway,  
Hong Kong  
Tel : (852) 2525 8603  
Website : www.kingandcountry.com

### KINGS X

206 Alamo Plaza, San Antonio, TX 78205, USA  
Tel : (210) 226 7000 Fax : (210) 226 7117  
E-mail : sales@kingsx.com  
Website : www.kingsx.com



© 2012 • KING & COUNTRY



# Tradition of London Ltd

Traditional Toy soldiers & Model figures for collectors

**New in our 54mm Model Soldier Series**



**WW1 British,  
in 54mm**

**The Arab Legion,  
in 54mm**



**Available soon:**

The Duke of Marlborough & Lawrence of Arabia

*Tradition Toy Soldiers are available in North America from the following dealers:*

**Bryerton's Military Miniatures**  
2121 S. Racine Avenue  
Chicago . Illinois 60608  
Phone (312) 666 2800

**Dutkins' Collectables**  
1019 West Route 70  
Cherry Hill . New Jersey 08002  
Phone (856) 428 9559

**Hobby Bunker, Inc.**  
33 Exchange Street  
Malden, MA 02148  
Phone: 1-781-321-8855  
Fax: 1-781-321-8866

**Military Miniatures**  
Mill Creek Road . PO Box 8  
Wake . Virginia 23176  
Phone (804) 776 6129

**Julius Vesz**  
100 Front Street West  
Toronto M5J 1E3 . Canada  
Phone (416) 362 0581

**Tradition of London Limited . 5A Shepherd Street . Mayfair . London W1J 7HW . England**

Shop hours: Monday to Friday 9.00 - 5.30. Saturday 9.30 - 3.00

Tel: 020 7493 7452 . Fax: 020 7355 1224 . Email: [shop@traditionoflondon.com](mailto:shop@traditionoflondon.com)

[www.traditionoflondon.com](http://www.traditionoflondon.com)